

**22 and 26" Pro-frame Parts List –**

**The parts list below contains the part numbers of all the packages and components required to assemble the frame.**

**BOM1001 Pro26C-Side Kit**

- (Qty. 2) Perforated Rail – Pro Frame  
Length is frame size in inches minus 3" (i.e. 6' frame = 69", except 12' = 138")
- (Qty. 2) PRT1299 Perforated Rail – Pro-Frame 40.500"

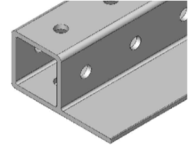

- (Qty. 1) Perforated Tube – Pro-Frame  
Length is frame size in inches (i.e. 6' frame = 72", except 12' = 141")
- (Qty. 2) PRT1300 Perforated Tube – Pro-Frame 43.500"
- (Qty. 2) PRT1299 Perforated Tube – Pro-Frame 40.500"
- (Qty. 2) PRT1297 Perforated Tube – Pro-Frame 34.500"
- (Qty. 2) PRT1295 Perforated Tube – Pro-Frame 24.000"
- (Qty. 2) PRT1294 Perforated Tube – Pro-Frame 22.500"
- (Qty. 1) PRT1293 Perforated Tube – Pro-Frame 21.000"
- (Qty. 2) PRT1290 Perforated Tube – Pro-Frame 15.000"
- (Qty. 6) PRT1285 Perforated Tube – Pro-Frame 13.500"

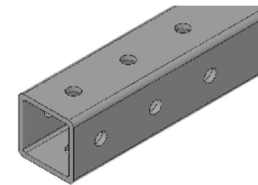

- (Qty. 2) PRT1226 Slotted Beam – 1-1/2 x 1-1/2 x 6"
- (Qty. 2) PRT1227 Slotted Beam – 1-1/2 x 1-1/2 x 9"
- (Qty. 2) PRT1224 Slotted Beam – 1-1/2 x 1-1/2 x 15.750"
- (Qty. 2) PRT1225 Slotted Beam – 1-1/2 x 1-1/2 x 20.5"

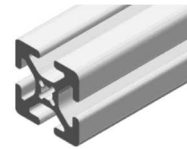

- (Qty. 5) PRT1022 Spacer Bar – 22/26



- (Qty. 2) PRT1009 Pivot Arm Nub



- (Qty. 14) PRT1010 Cross Block - Short

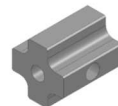

- (Qty. 4) PRT1471 End Cap – 1-1/2 x 1-1/2 Slotted Beam



- (Qty. 10) HDW1162 T-Nut - 5/16-18 15 Series Double

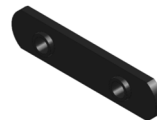

- (Qty. 2) HDW1161 T-Nut – 5/16-18 15 Series



- (Qty. 2) HDW1159 T-Nut – 10-32 10 Series



(Qty. 4) Rollers - Frame size plus 2 inches (i.e. 6' = 74")

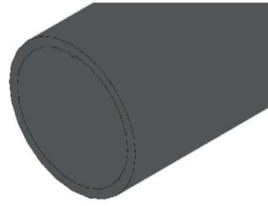

(Qty. 1 roll) PRT1267 Vibration Reducing Tape



(Qty. dependant on machine size) PRT1025 Table Top – 22/26

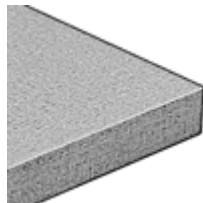

**BOM1410 Wheel Kit**

(Qty. 1) BOM1042 Lower Carriage Rear Wheel Bracket Assembly



(Qty. 1) BOM1043 Lower Carriage Front Wheel Bracket Assembly (Qty. 1)



(Qty. 1) BOM1426 X-axis Caliper Assembly

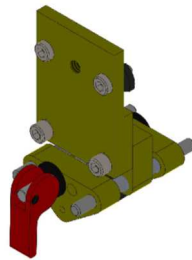

(Qty. 1) BOM1427 Y-axis Caliper Assembly

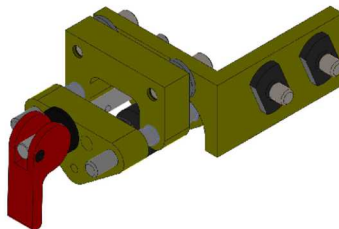

**BOM1045 Frame Hardware Kit**

(Qty. 6) PRT1349 Steel Strap



**BOM1035 Gas Spring Set**

(Qty. 2) BOM1036 Gas Spring Assembly



(Qty. 4) PRT1276 Gas Spring Ball Stud



**BOM1038 Collar Set**

(Qty. 5) BOM1037 Collar Assembly



**BOM1048 Gear Set**

(Qty. 3) BOM1047 Large Spur Gear Assembly



**BOM1499 Machine Foot Set – HD**

(Qty. 6) PRT1602 Machine foot – Pro-Frame HD



**BOM1500 Threaded Insert Set – HD**

(Qty. 6) PRT1603 Threaded Insert End – HD (Qty. 6)

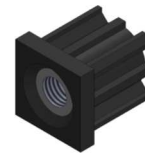

**BOM1501 Bumper and Shim Set**

(Qty. 2) PRT1277 Rubber Bumper

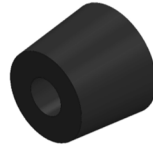

(Qty. 2) PRT1032 Small Rubber Cap



(Qty. 5) HDW1180 Washer – Frame Shim 1/8 THK



**BOM1039 Plastic Clamp w/ Cord and Cord Lock Set**

(Qty. 2) PRT1028 ABM clamp with PRT1268 Elastic Cord - Red

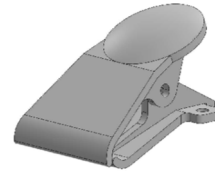

(Qty. 2) PRT1246 Acetal Wheel Lock



**BOM1030 EZ-Lock Plate Set**

(Qty. 2) BOM1031 Short Roller End Plate w/ Small Pinion Gear Assembly

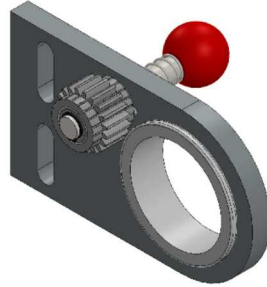

(Qty. 4) BOM1027 Short Roller End Plate Assembly

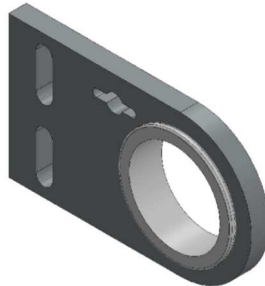

(Qty. 1) BOM1029 Long Roller End Plate w/ Small Pinion Gear Assembly

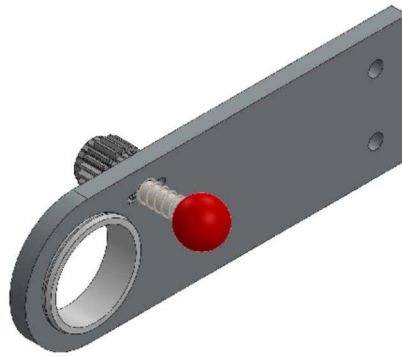

(Qty. 1) BOM1028 Long Roller End Plate Assembly

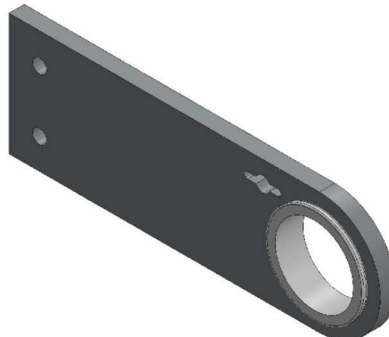

**BOM1032 Gusset Plate Set**

(Qty. 6) PRT1347 5-Hole Gusset

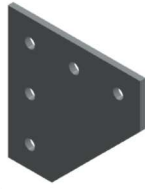

(Qty. 2) PRT1348 4-Hole Gusset



**BOM1033 Pivot Plate Set**

(Qty. 4) PRT1346 Pivot Plate



(Qty. 4) HDW1121 Shoulder Bolt – 3/8 x 3/8



(Qty. 4) HDW1168 Plastic Washer - Pivot Thrust (Black)



**BOM1034 Plastic Parts Set**

(Qty. 8) PRT1590 Roller End Cap - HD

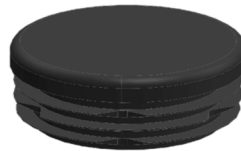

(Qty. 18) PRT1470 End Cap – Perf. Tube

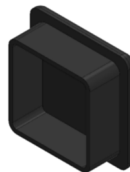

**BOM1023 Bolt Kit**

**Socket head cap screws:**

(Qty. 2) #10 x 3/4"



**Hex head screw:**

(Qty. 8) 5/16 x 3/4"

(Qty. 14) 5/16 x 1"

(Qty. 30) 5/16 x 2"

(Qty. 60) 5/16 x 2-1/4"

(Qty. 8) 5/16 x 2-1/2"

(Qty. 20) 5/16 x 3-1/2"



**Flat washers:**

(Qty. 200) 5/16  
(Qty. 6) 16MM



**Lock washers:**

(Qty. 20) 5/16



**Nylon insert lock nuts:**

(Qty. 100) 5/16



**Hex nuts:**

(Qty. 2) 5/16



**18" Pro-frame machine leg assembly –**

**NOTE: MAKE (6) PIECES**

Step 1: Install 16MM hex nut onto each of the (6) machine feet. Screw nut all the way down to the top of the hex on threaded foot.

Step 2: Install (1) 16MM flat washer onto each of the (6) machine feet.

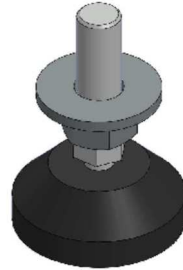

Step 3: Install the black plastic threaded insert into the end of the 13-1/2" perforated square tube with a hammer. Use a block of wood to protect the plastic insert.

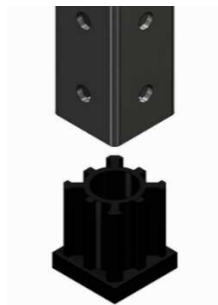

Step 4: Install a machine foot assembly into (6) threaded inserts.



Step 5: Install (1) tubing end cap into the open end of each foot assembly.

Step 6: Set aside. **22" and 26" Pro-Frame side rail support assembly –**

**IMPORTANT NOTE: Take care not to over-tighten nuts and bolts while assembling the aluminum Pro-frame. Unnecessary over-tightening will cause the frame pieces to twist and distort.**

**NOTE: MAKE ONE LEFT AND ONE RIGHT HAND ASSEMBLY**

Step 1: Install a cross block (2 total) into each end of the 40.5" tube using (1) 2-1/4 hex bolt, (2) flat washer (one per side) and (1) nylon insert lock nut. **NOTE: INSTALL SO THAT HEX HEADS OF THE BOLTS ARE FACING THE SAME DIRECTION ON EACH END.**

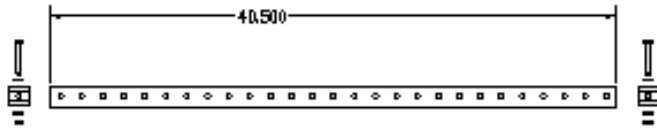

Step 2: Install a cross block into one end of the 21" tube using (1) 2-1/4 hex bolt, (2) flat washer (one per side) and (1) nylon insert lock nut.

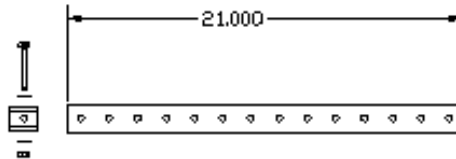

Step 3: Bolt 21" tube onto 43.5" tube through 2nd hole from one end. Use (1) 2" hex bolt and (1) flat washer.

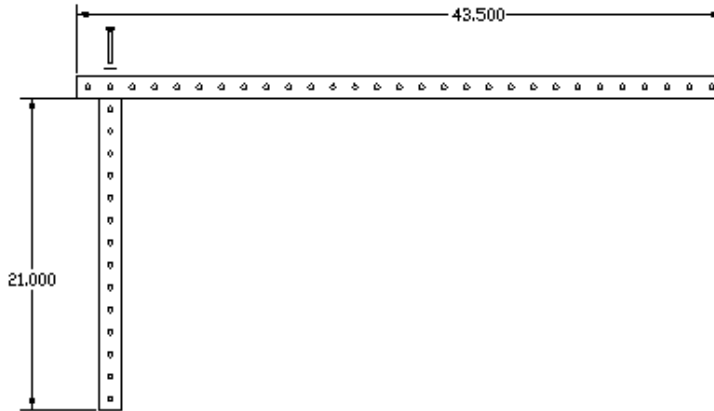

Step 4: Bolt 40.5" tube, from step 1, to 21" tube (9) holes down from connection to 43.5" tube. Use (1) 2" hex bolt and (1) flat washer.

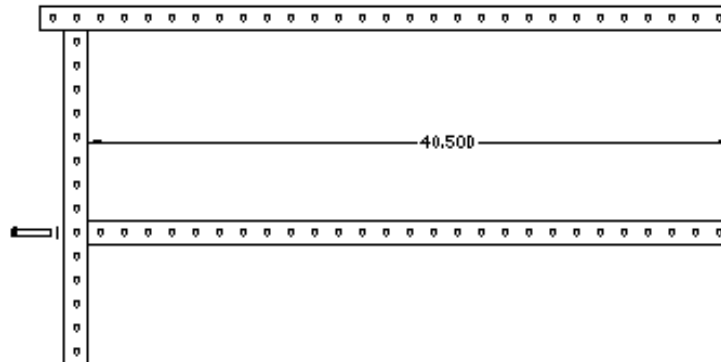

Step 5: Install 34.5" tube onto open end of 40.5" tube. Install into 6th hole from one end of 34.5" tube. Use (1) 2" hex bolt and (1) flat washer.



Step 6: Using (1) 5-hole gusset, attach 43.5" tube to 34.5" tube. Use (5) 2-1/4" hex bolts, (10) flat washers (one per side) and (5) nylon insert lock nuts. **NOTE: MAKE SURE TO ASSEMBLE (1) LEFT AND (1) RIGHT ASSEMBLY.**

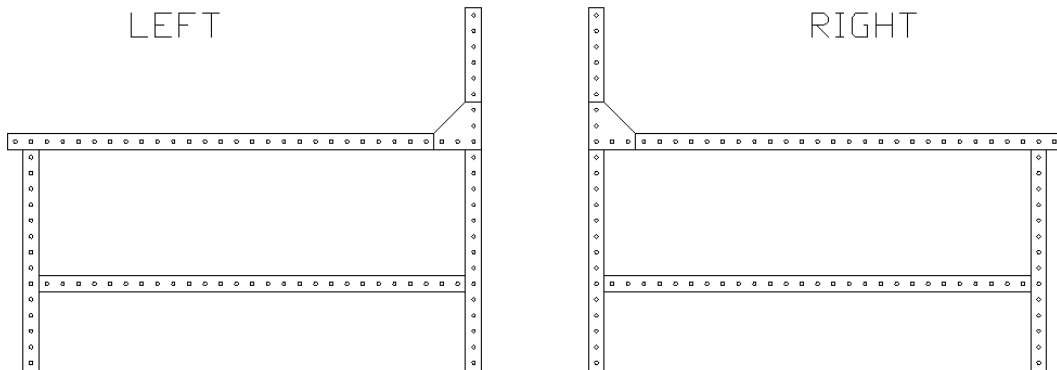

Step 7: Using (1) 5-hole gusset plate, attach 20.5" slotted beam to 43.5" tube. Beam should mount through 11th hole from open end of 43.5" tube for a 26" and the 13th hole for a 22". Use (3) 2-1/4" hex bolts, (6) flat washers (one per side) and (3) nylon insert lock nuts to attach plate to perforated square tubing. Place (2) 3/4" hex bolts with (2) lock washers (one each) in open holes on gusset plate. On opposite side, attach (1) double T-nut bump side facing away from gusset plate. Slide the 20.5" slotted beam onto the T-nuts and tighten. **NOTE: MAKE SURE TO ASSEMBLE (1) LEFT AND (1) RIGHT ASSEMBLY.**

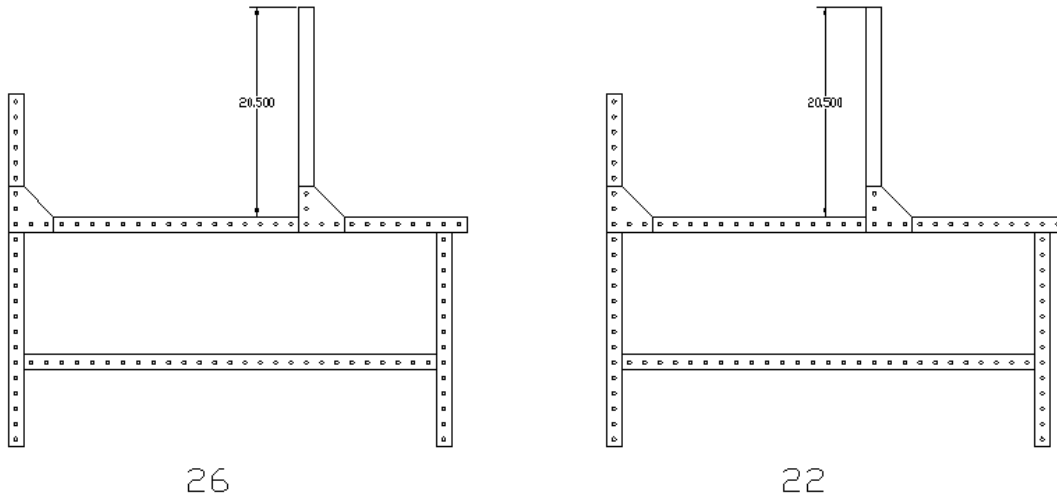

Step 8: Using (1) 5-hole gusset plate, attach 15" perforated tube to 43.5" tube. 15" Tube should mount so that there are 4 open holes between the 5-hole gusset plates as in the picture below. Use (5) 2-1/4" hex bolts, (10) flat washers (one per side) and (5) nylon insert lock nuts. **NOTE: MAKE SURE TO ASSEMBLE (1) LEFT AND (1) RIGHT ASSEMBLY.**

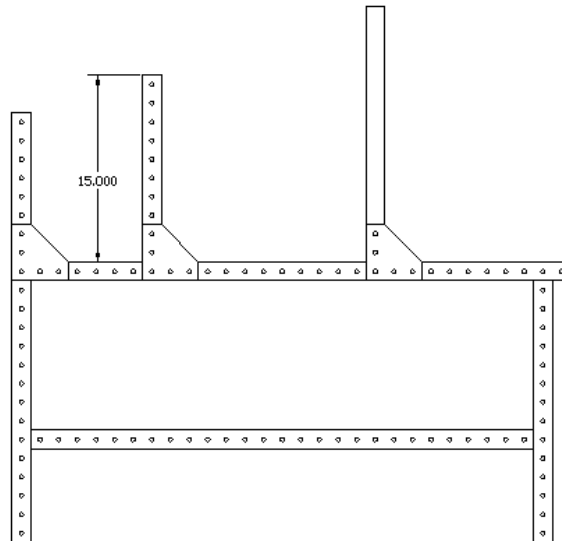

Step 9: Slide (1) 5/16 T-nut, with bump side facing in, into any slot of the 9" beam. This T-nut will be used later. Install (1) 9" beam between 15" tube and 34.5" tube through the 6th hole from open end of 15" tube. Use (2) 2" hex bolt and (2) flat washers. Position 9" beam so the slot with the T-nut is facing the same direction as the 5-hole gusset plates.

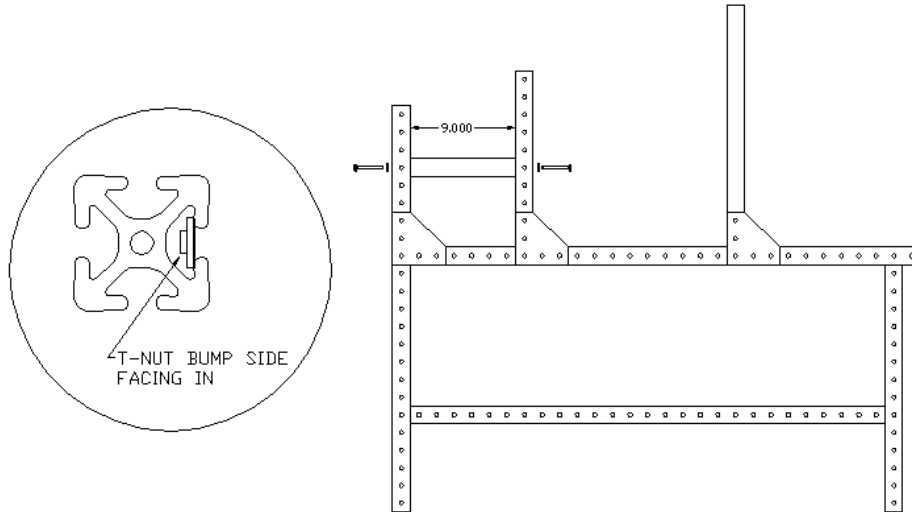

Step 10: Install short roller end plate with gear assembly onto top end of 34.5" tube (also install a cross block into the end of the tube). Use (2) 2-1/2" hex bolt, (4) flat washers, (2) nylon insert lock nuts. The balloon on the left illustrates how to install the cross block into the tube end. The balloons on the right show a top view of the 34.5" tube with the short roller end plate installed correctly. **NOTE: THE SHORT ROLLER END PLATES ARE ORIENTED DIFFERENTLY DEPENDING ON WHICH END YOU ARE WORKING ON. THE END PLATE WITH THE GEAR ASSEMBLY MUST BE INSTALLED ON THE RIGHT SIDE. CALL ABM IF YOU WANT TO MOUNT THE GEAR ASSEMBLY ON THE LEFT END.**

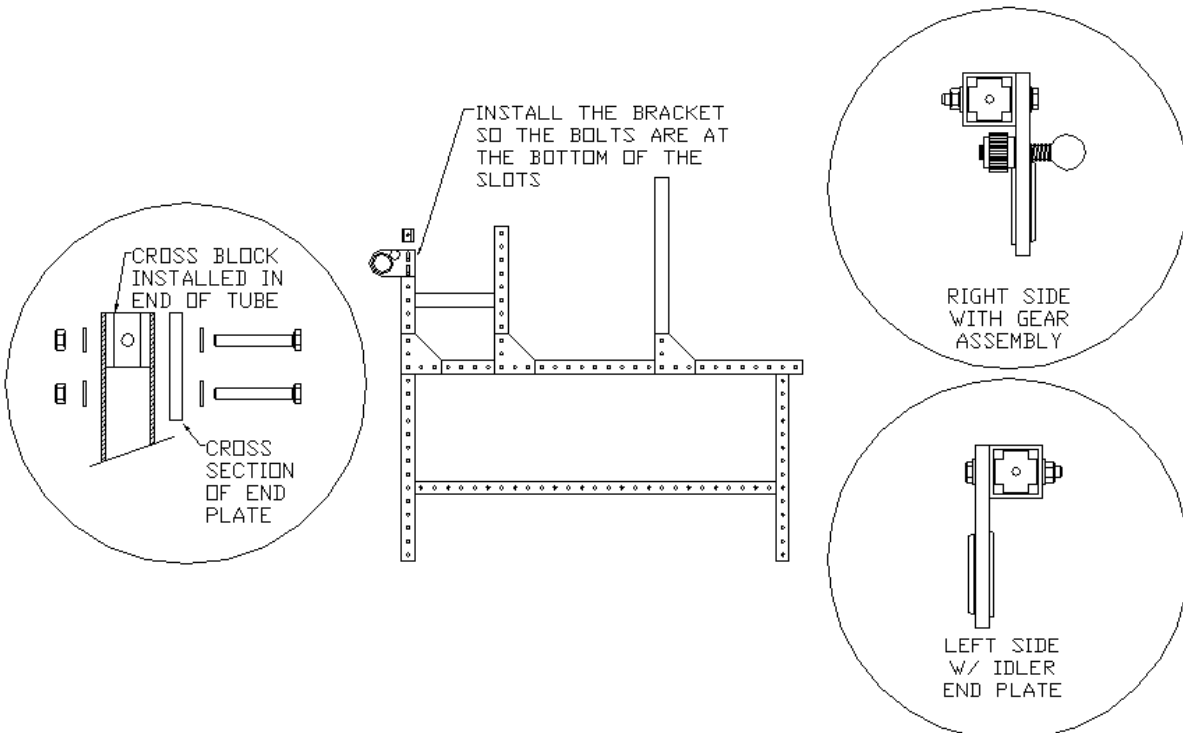

Step 11: Install (1) 1" hex bolt, (1) hex nut, and (1) flat washer into the end of the cross block. Install small rubber cap onto head of hex bolt. **NOTE: THE SMALL RUBBER CAP IS A VERY TIGHT FIT AND SHOULD BE STARTED ON ONE OF THE POINTS OF THE HEX BOLT HEAD AND ROLLED ONTO THE ENTIRE BOLT HEAD. PRESS DOWN FIRMLY TO MAKE SURE RUBBER CAP HAS SEATED COMPLETELY ON THE BOLT HEAD.**

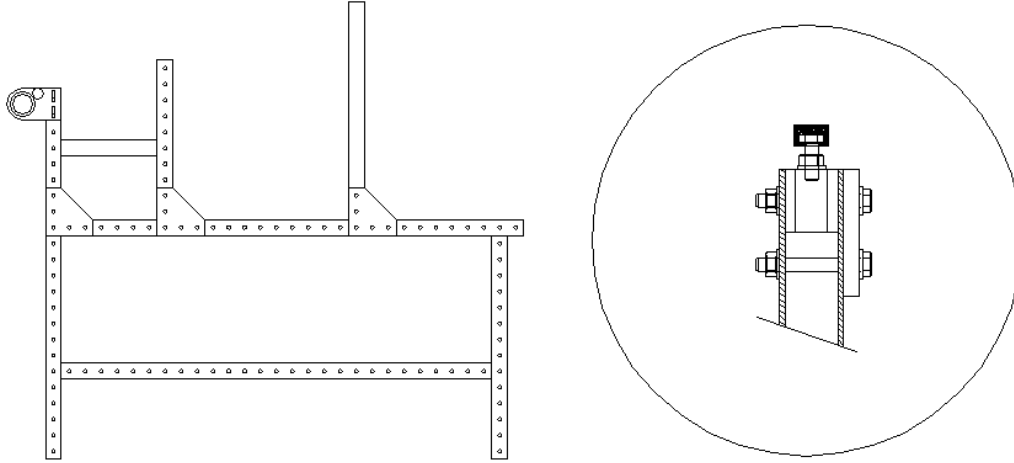

Step 12: Completed pro-frame left and right side rail support assemblies.

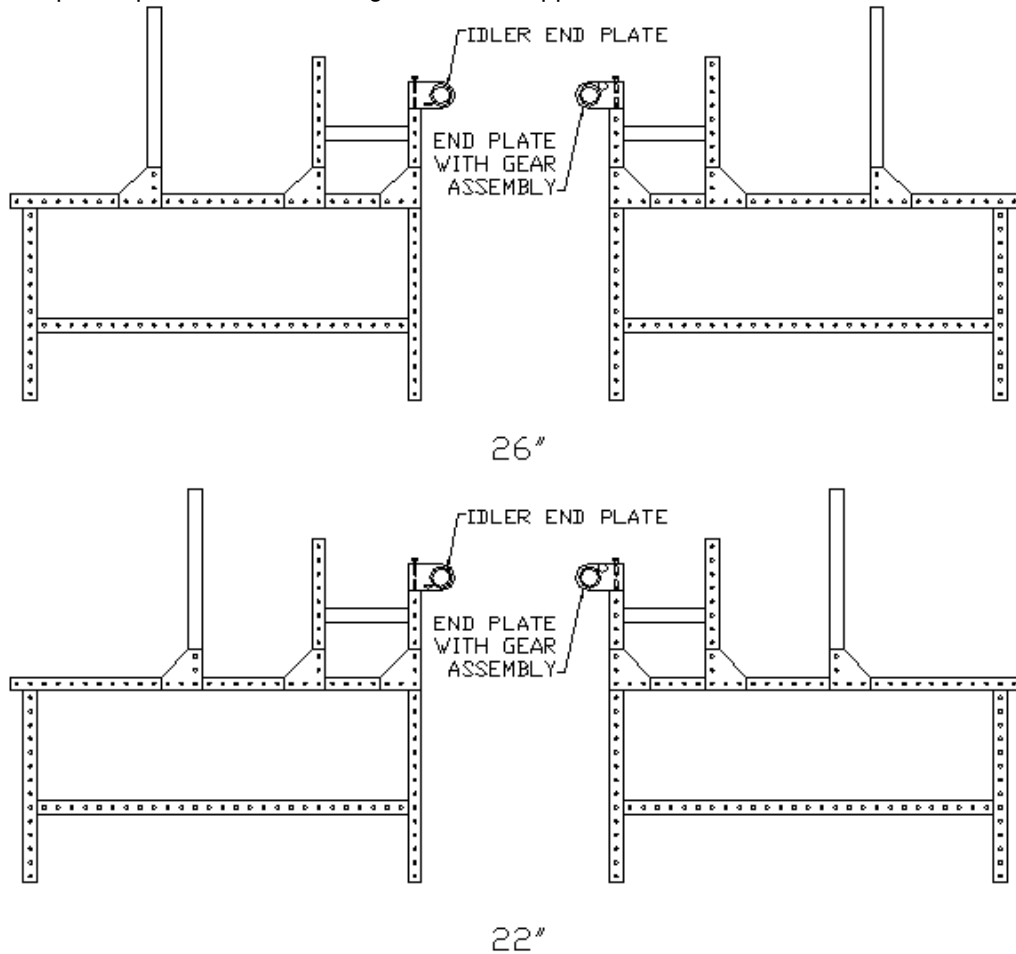

**22" and 26" Pro-frame pivot roller assembly –**

**NOTE: MAKE ONE LEFT AND ONE RIGHT HAND ASSEMBLY**

Step 1: Install pivot arm nub onto threaded end of 15-3/4" slotted beam – only one end of the beam is threaded. Use bolt with supplied nub. **NOTE: REMOVE THE 5/16 T-NUT AND SAVE.**

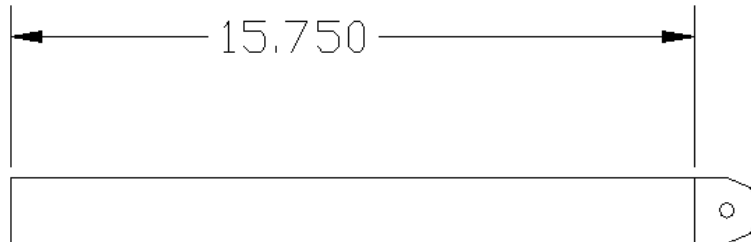

Step 2: Install 4-hole gusset onto 15-3/4" slotted beam approximately 1" from end with nub. Use (2) 3/4" hex bolts, (2) lock washers, and (1) double t-nut. **NOTE: MAKE (1) LEFT and (1) RIGHT HAND ASSEMBLY.**

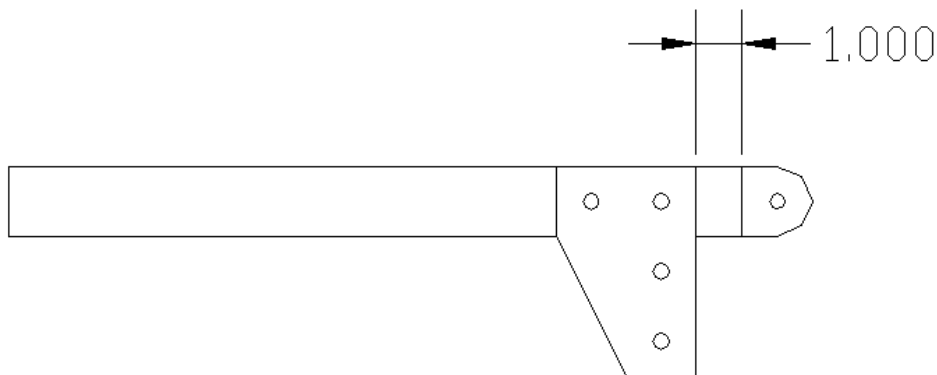

Step 3: Install long roller end plate with and without gear assembly onto open end of 15-3/4" slotted beam - flush to end. Use (2) 1" hex bolts, (2) lock washers, (2) flat washers, and (1) double T-nut. **NOTE: MAKE SURE THE TOP FABRIC ROLLER END PLATE WITH GEAR ASSEMBLY SHOULD BE ON THE RIGHT PIVOT ROLLER ASSEMBLY.**

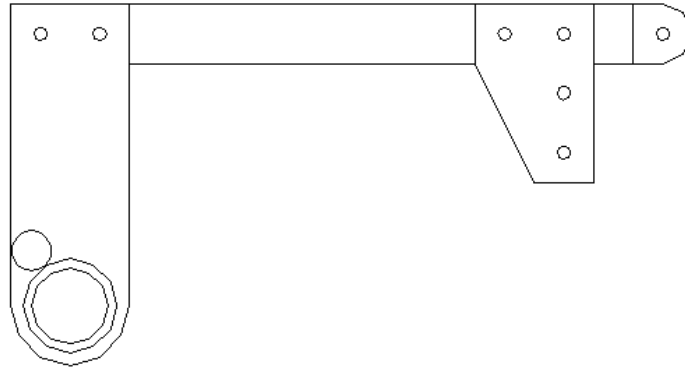

Step 4: Install (2) pivot plates onto nub end. Use (2) 3/8 x 3/8 shoulder bolts and (2) black plastic pivot washers. Install plastic washer between pivot plate and pivot arm nub.

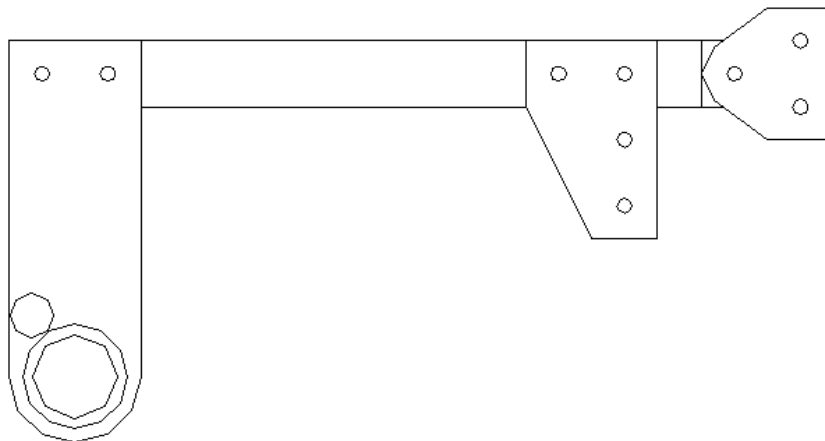

Step 5: Install pivot roller assembly onto 15" perforated tube located on side frame assembly. Use (2) 2-1/2" hex bolts, (4) flat washers, and (2) nylon insert lock nuts. Adjust the height of the rubber capped hex bolt so the 15-3/4" slotted beam is level to the ground.

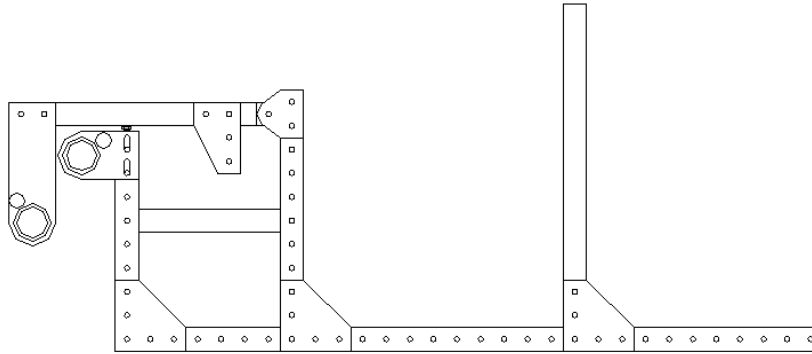

Step 6: Attach one gas spring ball stud to 4-hole gusset and secure with (1) nylon insert lock nut. Install the other ball stud with a flat washer into 5/16 t-nut located in 9" beam – see illustration for correct position. Make sure to use (1) flat washer between lower ball stud and 9" beam. Tighten lower mount.

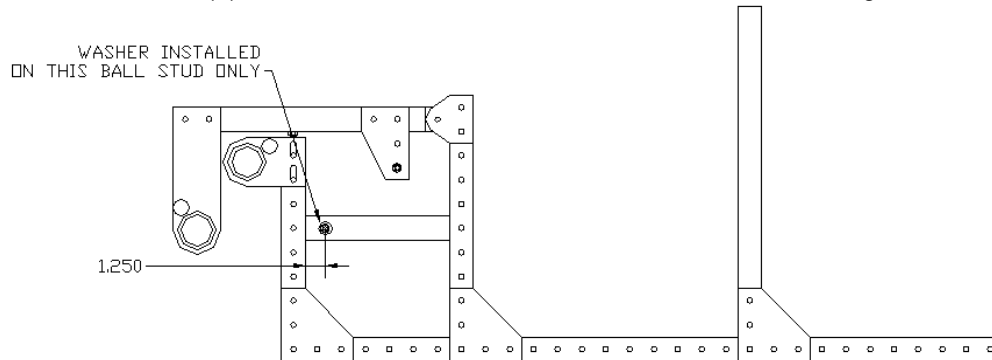

Step 7: Attach the gas springs to the frame by firmly pressing the black plastic socket ends onto the ball studs. **NOTE: INSTALL THE PISTON ROD END OF THE GAS SPRING FACING DOWN.** Lift the pivot roller arm to line up the socket with the ball studs. If everything is done correctly, the arm will stay in the lifted position when raised and it will lock in the lower position when lowered. If the arm fails to stay in the lifted position, move the lower ball stud toward the pivot arm bracket slightly.

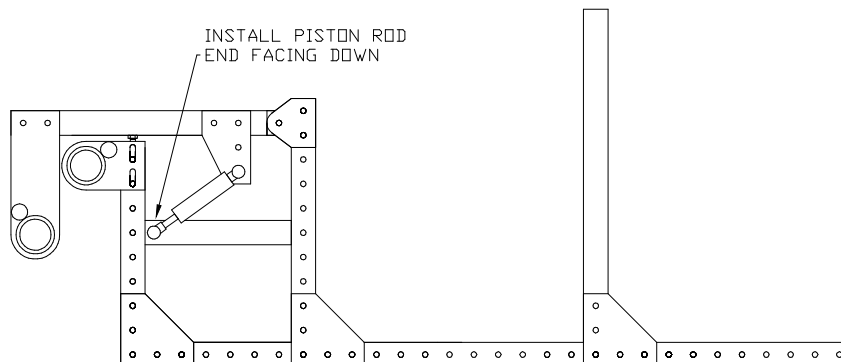

**22" and 26" Pro-frame lower carriage assembly -**

Step 1: Install a 6" slotted beam onto the (2) 40.5" perforated rail tubes thru 4th hole from open end for a 22" and the 5<sup>th</sup> hole from the open end for a 26". Use (2) 2" hex bolts, (2) flat washers. **NOTE: IF MACHINE IS EQUIPPED WITH INSTAGRIP CHANNEL LOCKS, INSTALL (2) ¼-20 T-NUT, INCLUDED WITH THE X-AXIS CALIPER ASSEMBLY, IN THE OUTSIDE CHANNEL OF THE 6" BEAM.**

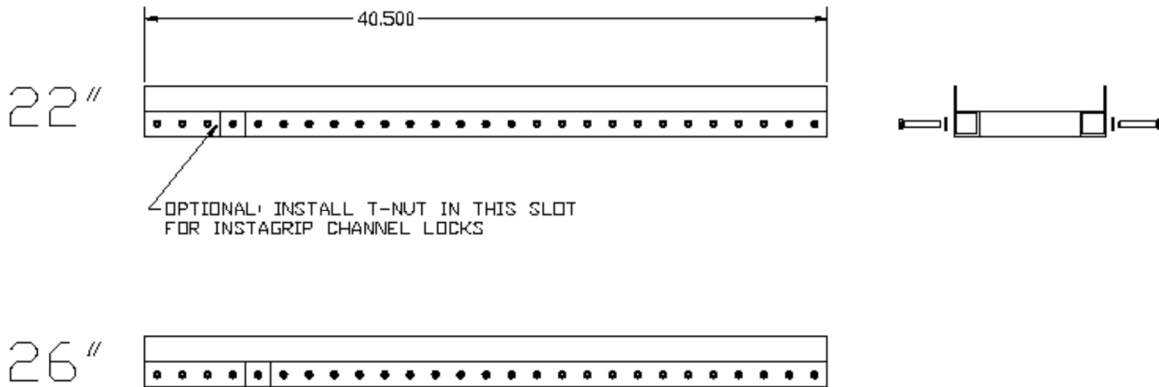

Step 2: Install a second 6" beam onto 40.5" perforated rail tube. Mount thru 1st hole on opposite end of tube. Use (2) 2" hex bolts and (2) flat washers.

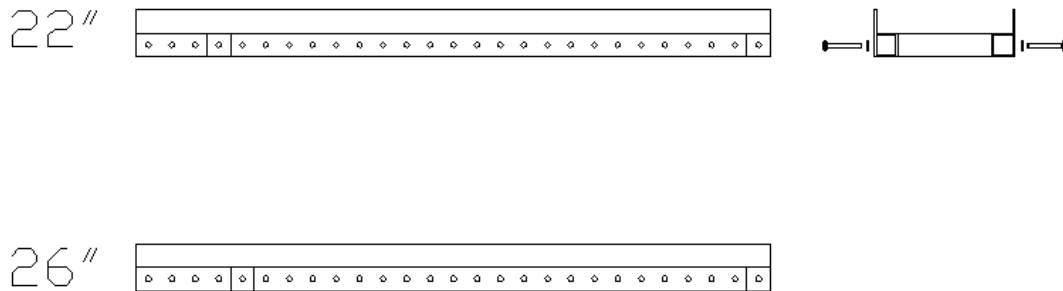

Step 3: Install lower carriage rear wheel bracket assembly onto 40.5" perforated rail tube thru the 5th hole from end of tube for a 22" and the 6th hole from end of tube for a 26". Use (2) 2-1/4" hex bolts, (4) flat washers and (2) nylon insert lock nuts. **NOTE: SEE DRAWINGS FOR PROPER BRACKET AND WHEEL ORIENTATION. MAKE SURE TO CHECK FOR SQUARENESS WHEN TIGHTENING THE WHEEL BRACKET TO THE RAILS – USE A COMBINATION OR CARPENTERS' SQUARE IF AVAILABLE.**

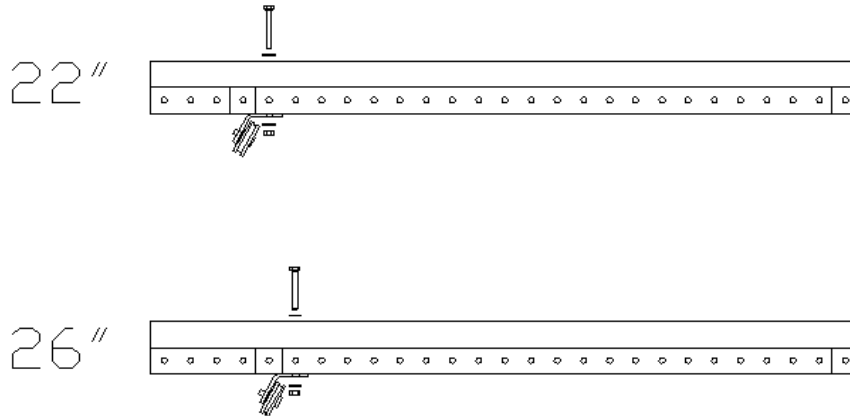

Step 4: Install lower carriage front wheel bracket assembly onto 40.5" perforated rail tube thru the 5th hole from end of tube for a 22" and 4th hole from end of tube for a 26". Use (2) 2-1/4" hex bolts, (4) flat washers and (2) nylon insert lock nuts. **NOTE: SEE DRAWINGS FOR PROPER BRACKET AND WHEEL ORIENTATION.**

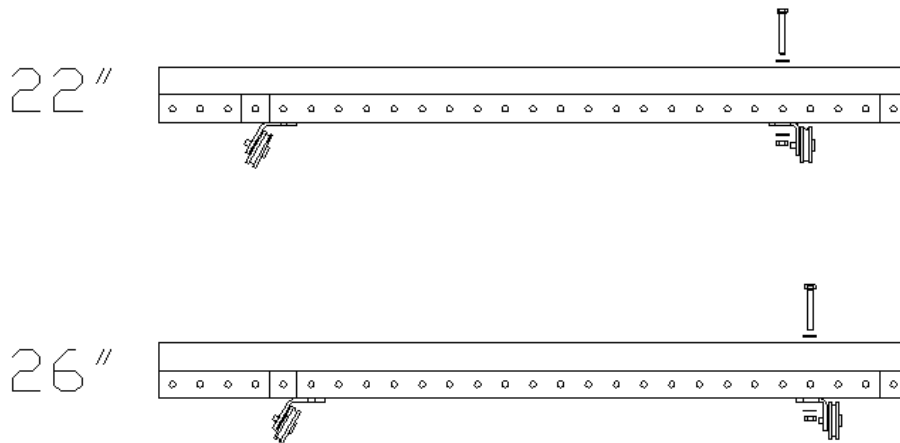

**26" Pro-frame final assembly –**

Step 1: Install (1) cross block (2 total) into each end of the long rail tubes using (1) 2-1/4 hex bolt, (2) Flat washer (one per side) and (1) Nylon insert lock nut. **NOTE: INSTALL BOLTS SO THAT HEX HEADS ARE FACING THE SAME WAY AS DRAWING INDICATES.**

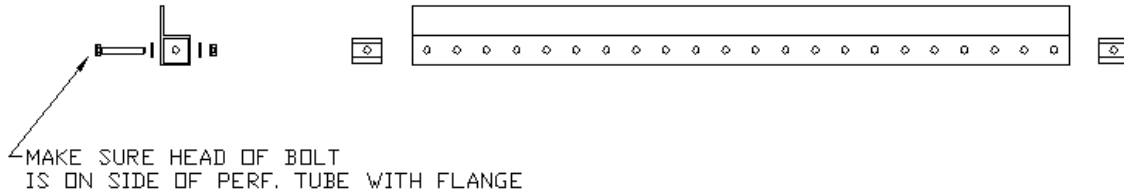

Step 2: Bolt long perforated rail tubes to side rail support frame assemblies using (4) 2" hex bolts, and (4) flat washers. See drawing for rail locations and orientation for a 26" and 22" machine setup. **NOTE: BOLTS PASSING THROUGH THE 5-HOLE STEEL PLATE MUST USE 2-1/4" HEX BOLTS.**

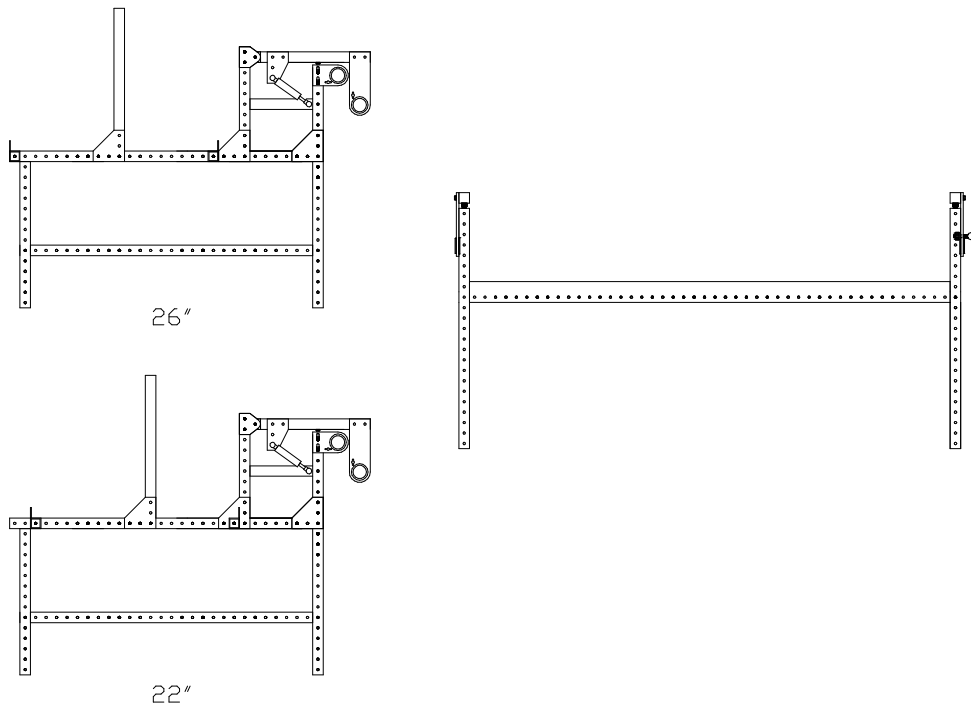

Step 3: Bolt long perforated square tube to side rail support frames using (2) 3-1/2" hex bolts, (4) flat washers, and (2) nylon insert lock nuts. **NOTE: POSITION THE TUBE DIRECTLY BELOW THE FRONT LONG PERFORATED RAIL TUBE. SEE SIDE VIEW BELOW.**

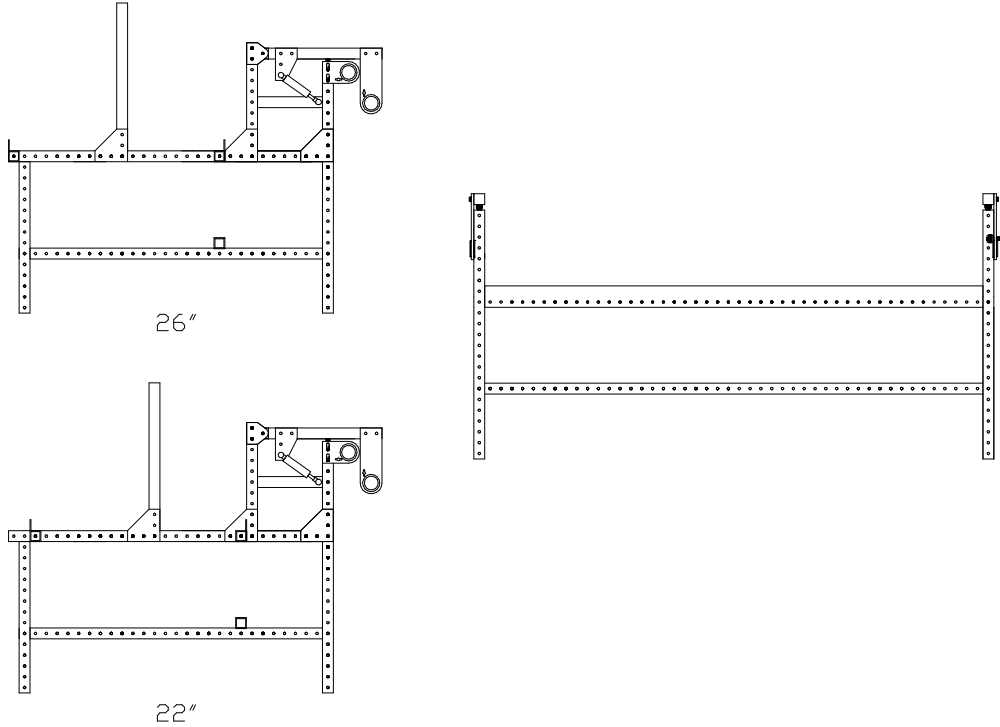

Step 4: Install (1) cross block (2 total) into each end of the 24" tube using (1) 2-1/4" hex bolt, (2) flat washer (one per side) and (1) nylon insert lock nut. **NOTE: INSTALL SO THAT HEX HEADS ARE FACING THE SAME DIRECTION ON EACH END.**

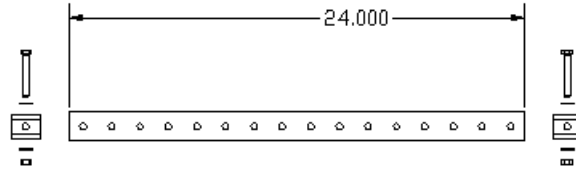

Step 5: Install the 24" tube into 6<sup>th</sup> hole from the bottom of the two 22.5" tubes. Use (2) 2" hex bolts and (2) flat washers. The center leg assembly is now complete.

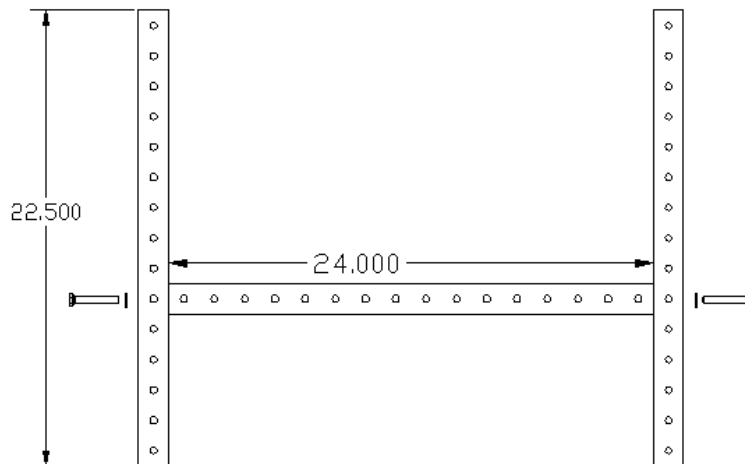

Step 6: Install the center leg assembly at approximately the center of the perforated rail. Use (1) 3-1/2" hex bolts, (2) flat washers, and (1) nylon insert lock nut to attach the assembly to the lower beam. Use (1) 3-1/2" hex bolt, (2) flat washers and (1) nylon insert lock nut to attach the leg assembly to each of the long perforated rails.

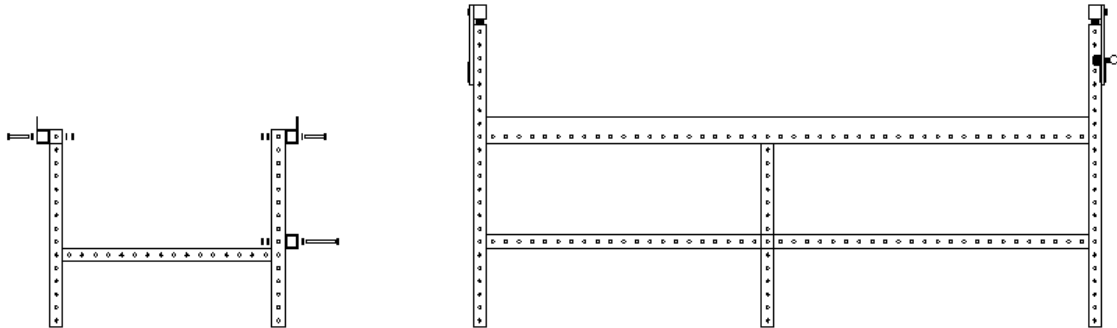

Step 7: Install the (5) round spacer bars with (1) 1/8" thick frame shim washer on each bar between the upper rails 9 holes from either end. Use (2) 2" hex bolts and (2) flat washers per spacer. Try to evenly space the remaining (3) round spacers down the length of the perforated rails. Start with one bar in the approximate center. Use the remaining two bars to split the difference between the center bar and the bars at the end. **NOTE: DO NOT OVERTIGHTEN THE BOLTS AS THIS WILL CAUSE DISTORTION OF THE PERFORATED RAIL AND REDUCE STRAIGHTNESS.**

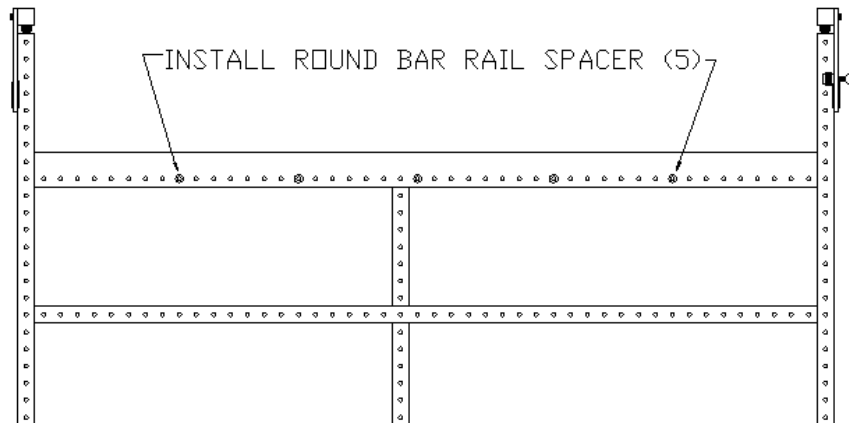

Step 8: Install (4) steel straps to the lower perforated tube and upper perforated rail tube using (6) 2-1/4" hex bolts, (12) flat washers, and (6) nylon insert lock nuts. **NOTE: SEE DRAWING FOR HOLE LOCATIONS.**

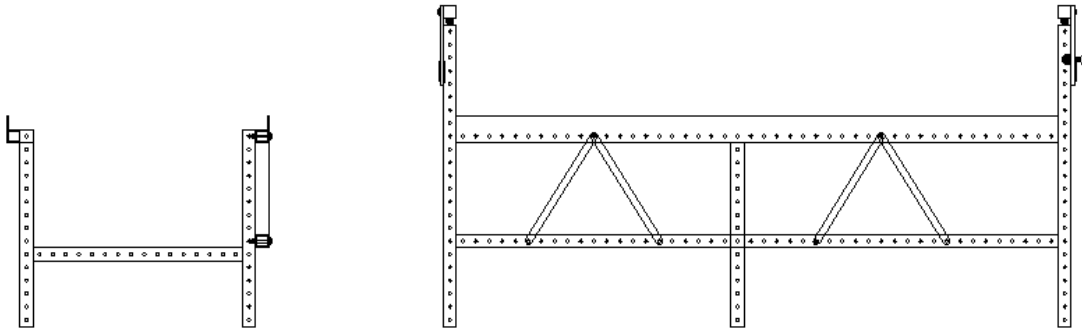

Step 9: Square lower carriage assembly to rail tubes. Ensure that rails ride in the center of the wheels for smoothest performance. If rail to wheel relationship is consistent down the entire length of rail, adjust the lower carriage front wheel assembly. If the rail to wheel relationship differs as the carriage moves down the rail, adjust the long rail tubes by adding or removing washers to the round bar rail spacers.

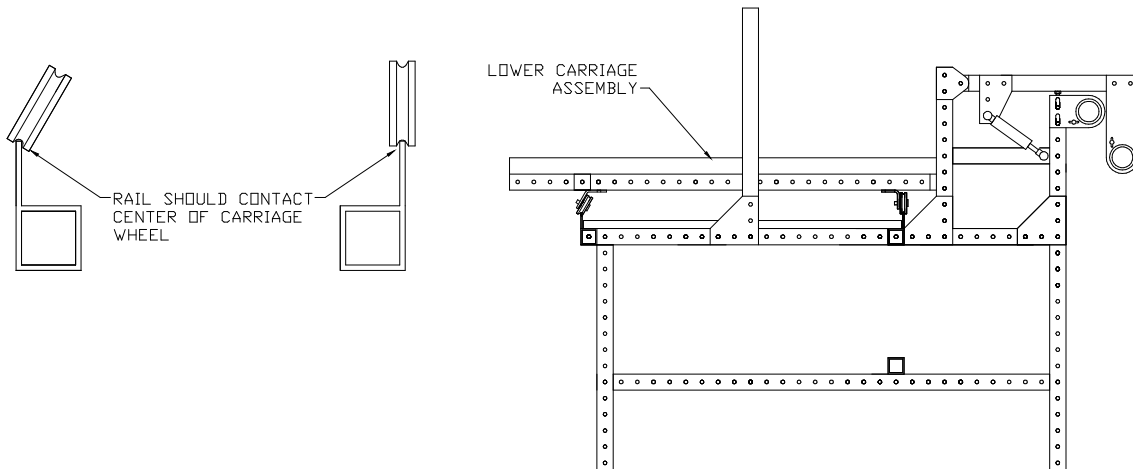

Step 10: Install (2) steel straps onto the long perforated rail tubes using (2) 2-1/4" hex bolts, (4) flat washers and (2) nylon insert lock nuts. See illustration for proper location and orientation.

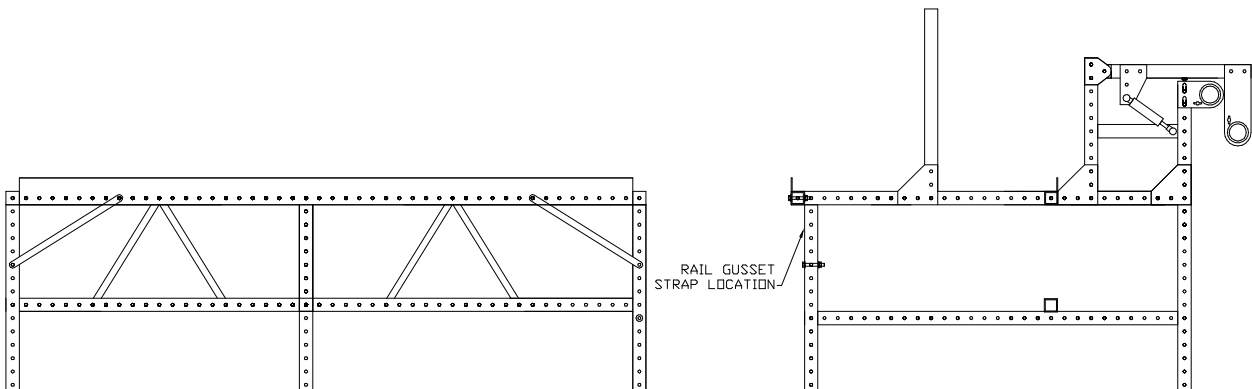

**NOTE: IF YOUR INNOVA CAME WITH A CROSS HATCH RULER, INSTALL IT NOW. MARK YOUR PLACE IN THE FRAME ASSEMBLY MANUAL AND GOTO THE CROSS HATCH RULER ASSEMBLY SECTION NOW.**

Step 11: Install the short roller end plates onto the 20.5" vertical slotted beams. Make the take up roller end plate 1-1/2" from the top of the slotted beam and set the bed roller plate at 5-1/2" from the top of the slotted beam. Use (2) 5/16 x 1" hex bolts, (2) lock washers, (2) flat washers, and (1) 5/16 double t-nut per plate. **NOTE: MAKE SURE TO INSTALL THE SHORT ROLLER END PLATE WITH GEAR ASSEMBLY IN THE TAKEUP ROLLER POSITION ON THE RIGHT SIDE OF THE MACHINE.**

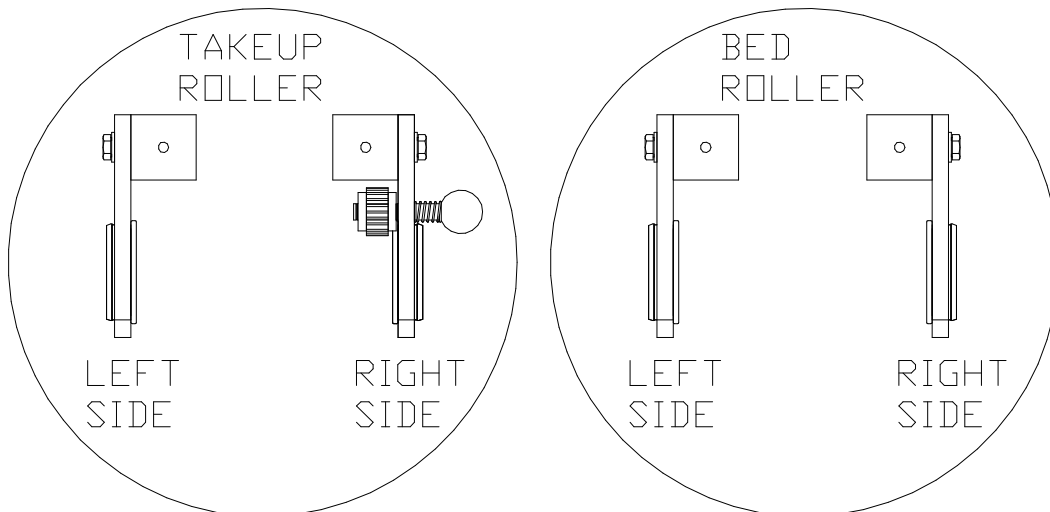
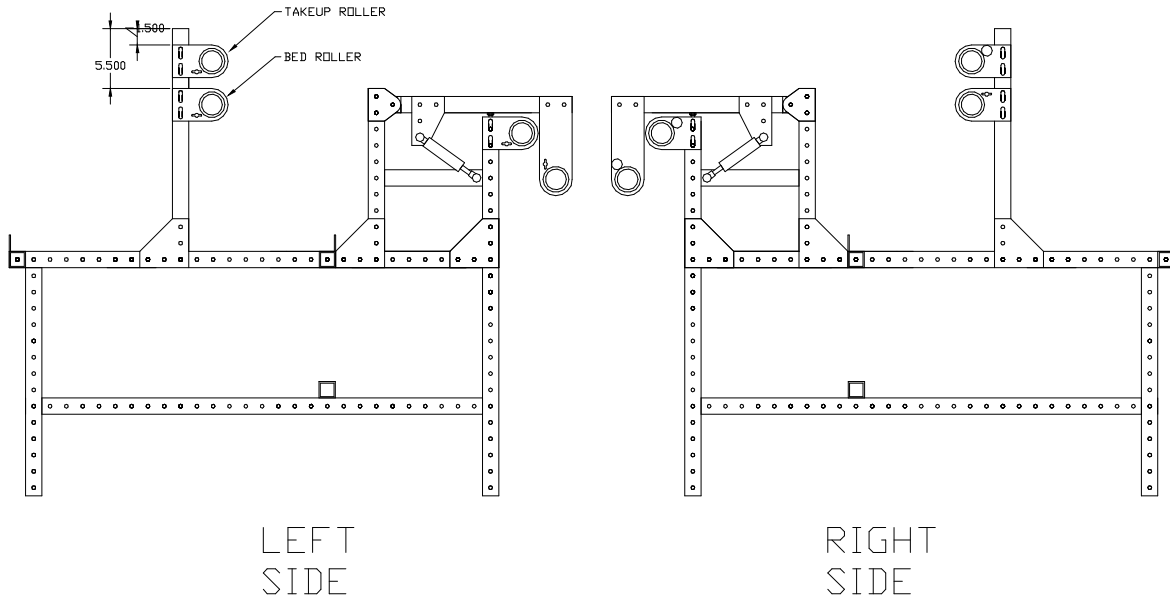

Step 12: Wipe down all (4) roller tubes with a cloth and some mild detergent to remove all oil films, dirt and grit. Dry the tubes thoroughly.

Step 13: Install the (3) large spur gear assemblies, hub first, 1-1/4" off the right end of (3) roller tubes. Tighten all (3) set screws on each gear equally. **NOTE: WHEN INSTALLING THE GEARS, MAKE SURE THE (3) SET SCREWS OF EACH GEAR ARE NOT POKING OUT ON THE INSIDE. THIS WILL MAKE INSTALLATION IMPOSSIBLE. THE GEAR INNER DIAMETER IS A CLOSE FIT TO THE TUBES. THE TUBES HAVE BEEN CHECKED AND DEBURRED TO ENSURE THAT THE GEAR FITS PROPERLY. DO NOT HAMMER THE GEAR ONTO THE ROLLER END. IF ALL ELSE FAILS TURN THE ROLLER AROUND AND TRY THE OTHER END.**

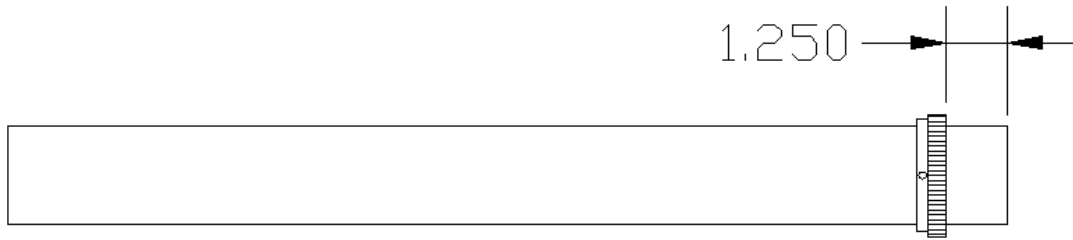

Step 14: Install the (3) roller tubes with gears into the roller end plates. Make sure the gears on the rollers are facing the end plates with the gear assemblies. Install a collar assembly onto the roller tube end and tighten the (3) set screws on the collar. **NOTE: MAKE SURE TO LEAVE A SMALL GAP BETWEEN THE COLLAR AND THE PLASTIC BUSHING. THIS WILL HELP MAKE SURE THE ROLLER TURNS SMOOTHLY. CHECK ALL (3) ROLLERS TO ENSURE THEY TURN SMOOTHLY. THEY SHOULD ONLY TURN ONE WAY WHEN THE SMALL GEAR ENGAGES THE LARGE ROLLER GEAR.**

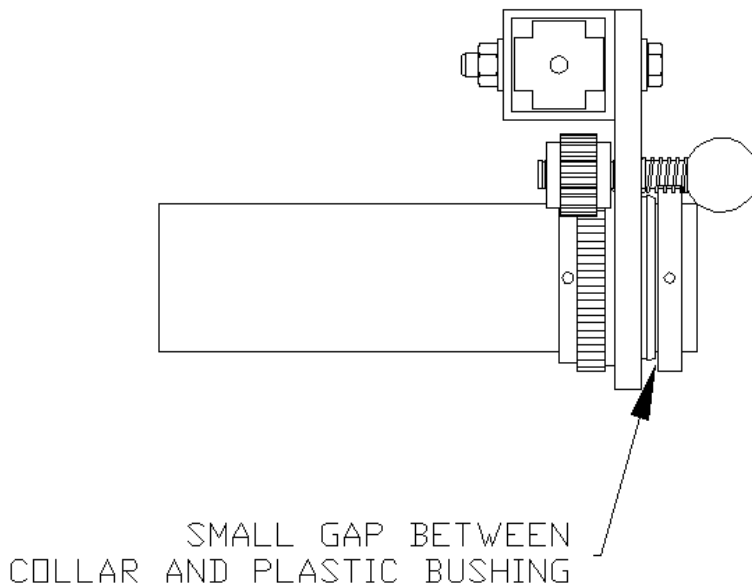

Step 15: Install the remaining roller tube into the bed roller end plates and install the (2) collars, one on either side of the plate, as shown below. Tighten the (3) set screws on each of the collars. Check to make sure the roller turns freely.

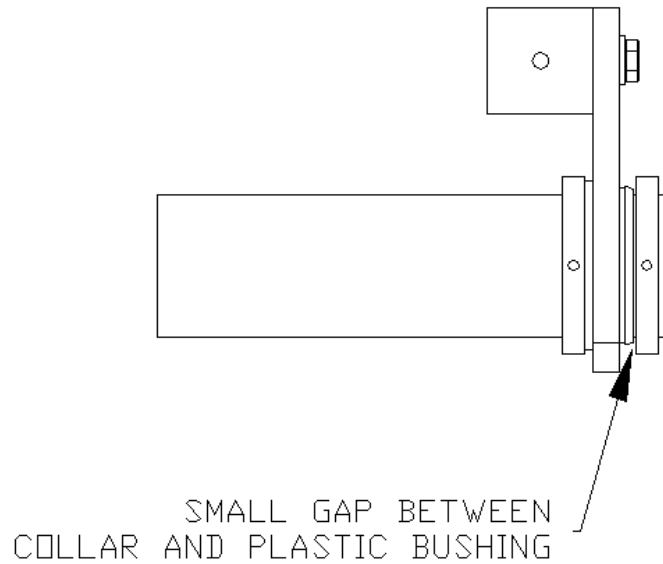

Step 16: Install vibration reducing tape onto the bottom and sides of the long perforated rail tubes. Keep the tape away from edge of rail where wheel rides. If the wheel contacts the rubber tape, poor rolling performance may result.

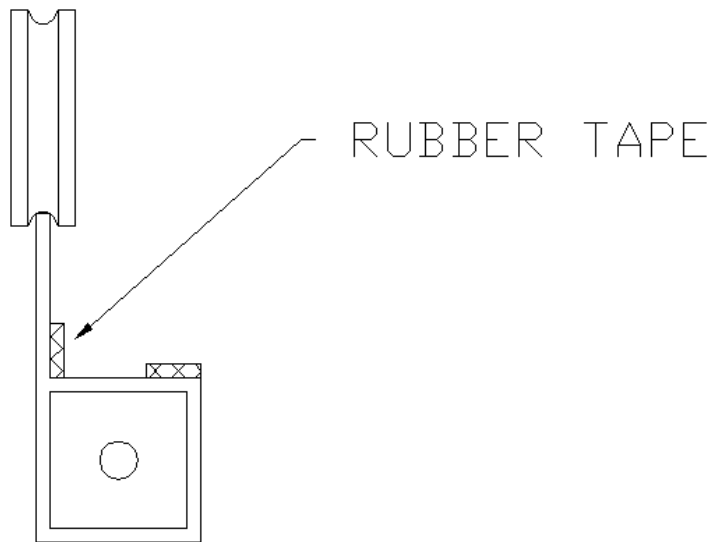

Step 17: Install machine leg assemblies onto frame. Use (2) 3-1/2" hex bolts, (4) flat washers and (2) nylon insert lock nuts per assembly

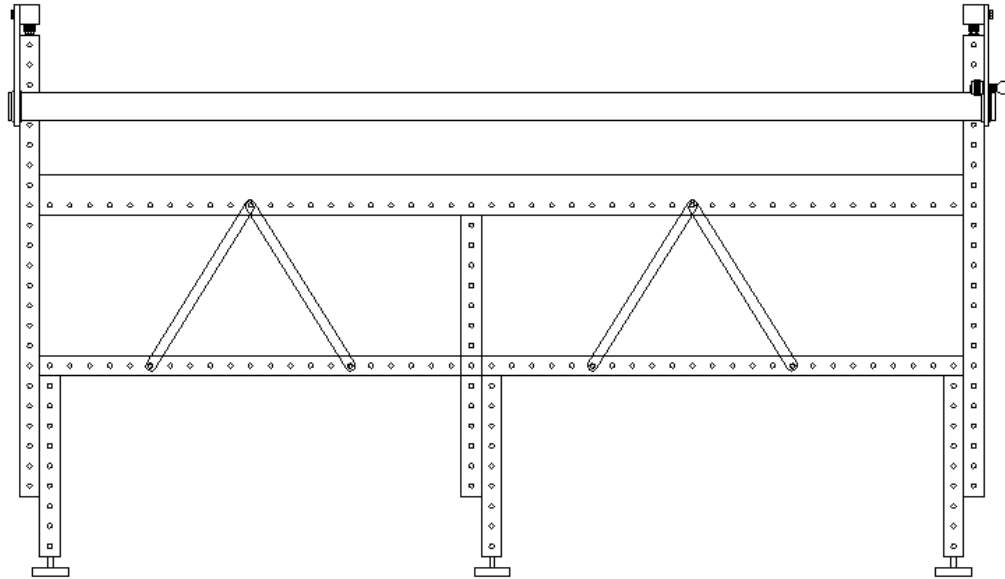

Step 18: Install table top between the long perforated rail tubes. Table should fit smoothly. Table should not be forced in between rails or damage may occur.

Step 19: Install the sewing machine onto lower carriage assembly.

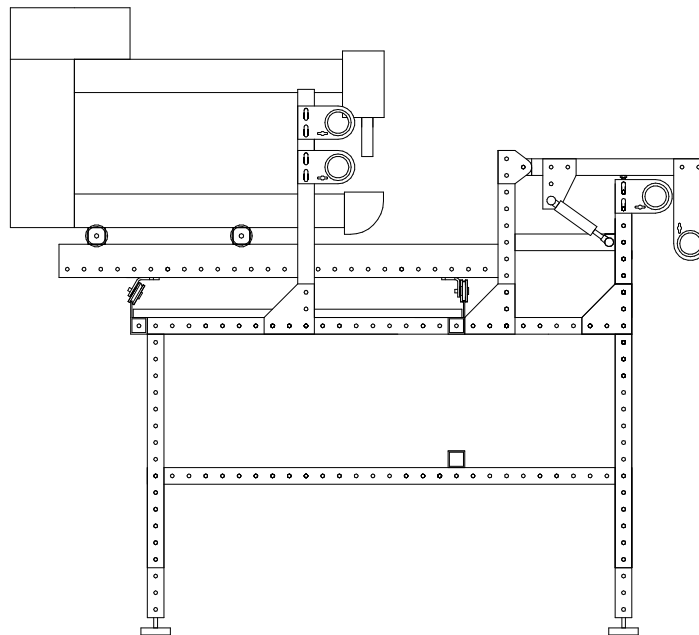

Step 20: Install the rubber bumpers onto 20.5" slotted beam, on the side of beam facing carriage assembly. Use (1) #10 x 3/4 socket head cap screw and (1) #10 t-nut. Adjust position of bumper so carriage contacts the bumper before hitting the end of frame. Install one bumper on each end.

Step 21: Install plastic clamp and elastic cord on each end using elastic cord clip to adjust the cord length.

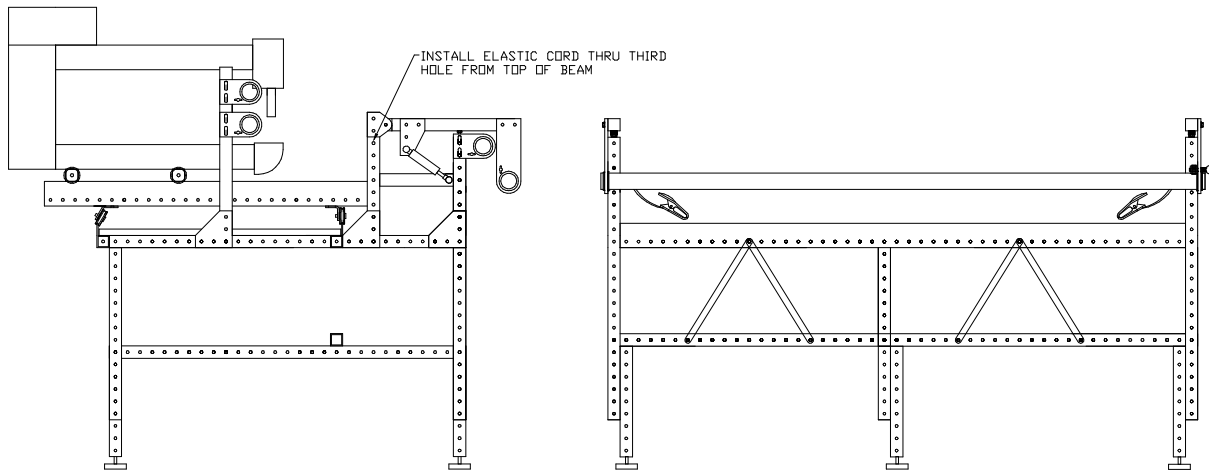

Step 22: Install the remaining (12) perforated tubing end caps into any open square ends of the frame.

Step 23: Install the (4) slotted beam end caps into the ends of the 15-3/4" and 20-1/2" slotted beams.

Step 24: Install the (8) roller end caps into the ends of the roller tubes.

### Pro-frame InstaGrip Channel Locks -

X-axis Caliper Assembly

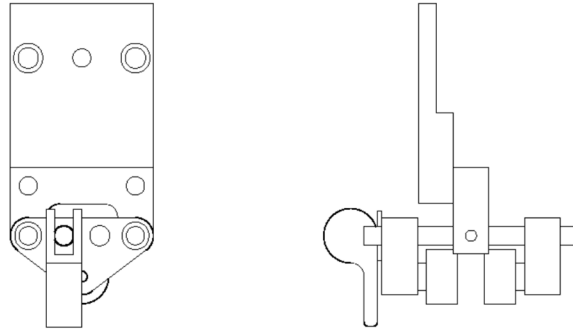

Y-axis Caliper Assembly

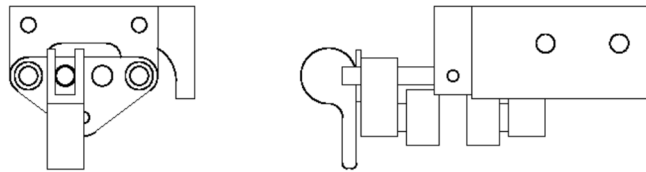

Step 1: To mount the Y-axis Caliper Assembly, choose either the right or left side of the Innova. Remove the front wheel for the left side or the rear wheel for the right side and install the caliper into the wheel beam using (2) 1/4-20 x 3/4 socket head bolts, (2) 1/4" flat washers and (2) 1/4-20 T-nuts. Re-install the wheel with the thick washer and spring washer – the thick washer is closest to the wheel bearing the spring washer touches the wheel beam. **ATTENTION AUTOPILOT USERS – THE CALIPER MUST BE INSTALLED ON THE LEFT SIDE OF THE MACHINE AND THE FRONT BELT CLAMP AND QUICK DISCONNECT ASSEMBLY MUST BE MOVED TO THE RIGHT SIDE OF THE CARRIAGE.**

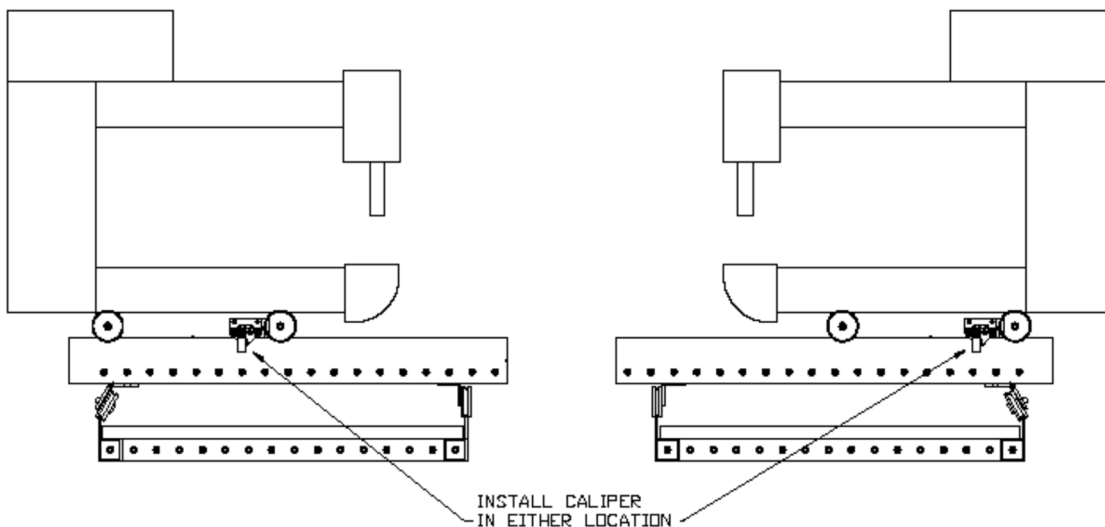

Step 2: Check to make sure the Y-axis caliper does not rub on the rail. A small amount of play in the caliper mount should be enough for adjustment. If it is rubbing, loosen the (2) 1/4-20 x 3/4 bolts from the previous step and hold up on the bracket while tightening the bolts.

Step 3: Mount X-axis caliper assembly onto the left side of the beam using the socket head bolts and the T-nuts that were pre-installed into the beam on page 20.

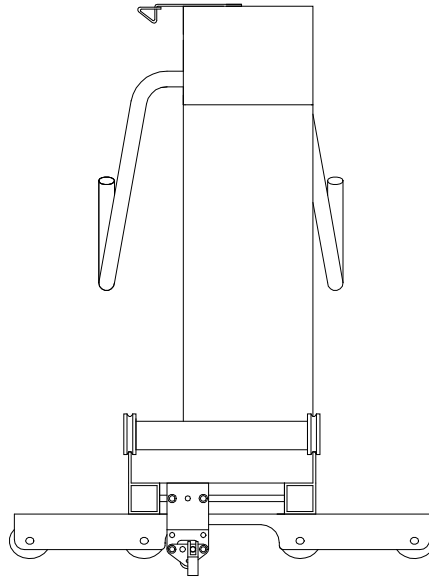

Step 6: Slide the X-axis caliper assembly as far to left side of the slot as possible, but do not allow any part of the assembly to come in contact with the wheel bracket. Tighten the (2) ¼-20 low head socket bolts and check to a make sure the caliper locks and unlocks without contacting any part of the wheel bracket. Adjust as necessary.

Step 7: Check to make sure the X-axis caliper assembly does not rub on the rail. A small amount of play in the caliper mount should be enough for adjustment. If it is rubbing, loosen the (2) ¼-20 low head bolts from the previous step and push up on the bracket while tightening the bolts.

Operational instructions:

Flipping the red lever on the lower X-axis lock will make the caliper squeeze the long rails of the frame and keep the machine from rolling left or right.

Flipping the red lever on the lower Y-axis lock will make the caliper squeeze the carriage rails of and keep the machine from rolling left or right.

### Pro-frame Spring Loaded Encoder Installation –

**NOTE: SPRING LOADED ENCODERS REQUIRE THE X-AXIS CALIPER MOUNT IN ORDER TO BE INSTALLED. IF YOUR MACHINE DOES NOT HAVE INSTA-GRIP CHANNEL LOCKS, THE SPRING LOADED ENCODER ASSEMBLY WILL NOT WORK ON THE X-AXIS. PLEASE CONTACT YOUR DEALER AND ORDER THE NECESSARY PARTS.**

The machine uses (2) wheel encoders, see figure below, to track the motion of the machine when stitch regulation is active. For shipping purposes, the encoders are wired into the machine but not attached to the sewing head or the lower carriage. Follow the steps below to properly install the stitch regulator.

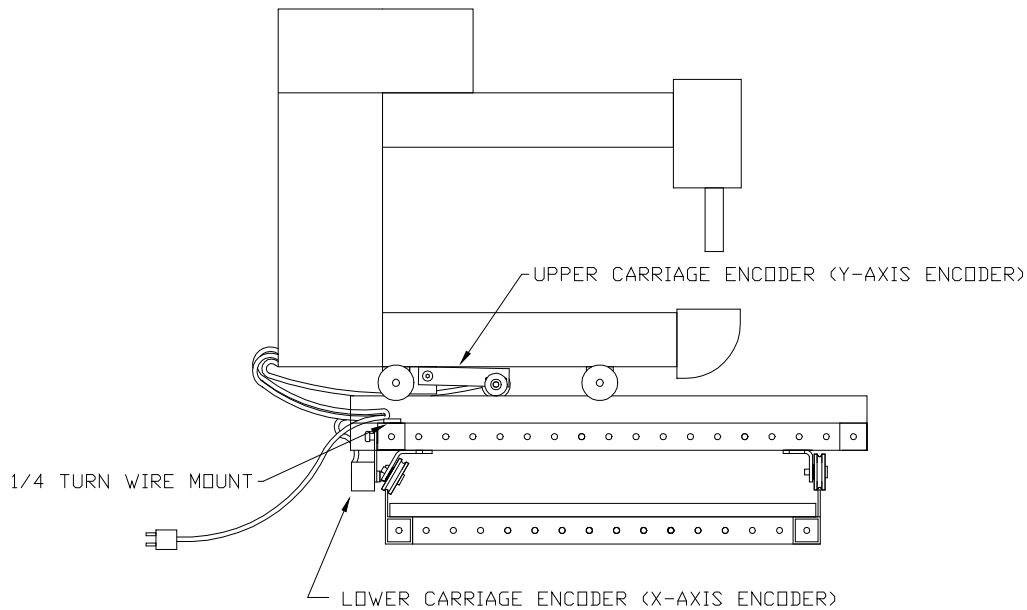

Step 1: Install the upper carriage encoder (Y-axis) onto the rear aluminum wheel beam of the sewing head with the supplied bolt and nut. Make sure that the U on the spring end is hooked over the top of the encoder plate. Make sure the straight leg of the spring is resting on the small hex nut on the angle bracket. See the picture below. **NOTE: REMOVAL OF THE REAR WHEEL MAY BE NECESSARY TO INSTALL THE NUT.**



Step 2: Make sure the gold mounting plate of the channel lock is installed close to the left end of the t-slot rail (see picture below). If you are installing spring loaded encoders on an older machine, replace the (2) 1/4-20 x 1/2" Low Head bolts with (2) 1/4-20 x 1/2" Socket Head bolts.

Step 3: Install the lower carriage encoder (X-axis) onto the X-axis caliper assembly of the lower carriage with the supplied shoulder bolt and spring (discard the gold washer and hex nut that came with, they are only used for shipping). Use the drawing below for the correct orientation. The U on the spring end should hook over the top of the encoder plate. The straight leg on the torsion spring should rest on the side of the head of the left socket head cap screw that holds the gold channel lock plate to the lower carriage.

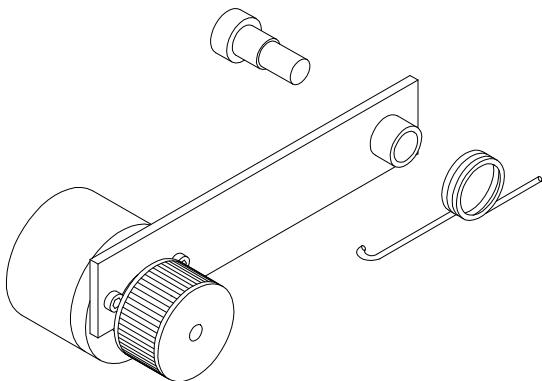

Step 4: Check to make sure the encoders move freely as the machine is moved left to right and front to back. The wheels of the encoders **MUST NOT** contact anything but the frame rail at any time and the encoder must pivot freely on the shoulder bolt. The wheel should lightly press against the rail with the help of the spring.

Step 5: Confirm that the upper and lower encoder wheels ride on the same flange that the plastic carriage wheels of the sewing machine and lower carriage roll on. Adjust the shafts of the wheels if necessary.

Step 6: Confirm that the electrical cable of the lower carriage encoder has enough slack to allow sufficient movement of the machine front to back without getting stretched. Install the 1/4 turn wire mount into the top channel of the lower carriage rear beam and nylon tie the main power and lower encoder cable to it. See the illustration on the first page of this assembly guide. **NOTE: BE SURE TO LEAVE ENOUGH SLACK ON THE ENCODER CABLE WHEN NYLON TYING SO THAT THE ENCODER WHEEL MAKES PROPER CONTACT WITH THE FLANGE. IF THE CABLE IS TOO TIGHT, THE ENCODER WHEEL WILL NOT ROLL PROPERLY CAUSING STITCH REGULATION PROBLEMS.**