

ABM International, Inc.
Autopilot Assembly Manual

1.0: Parts List

Computer (Qty. 1)

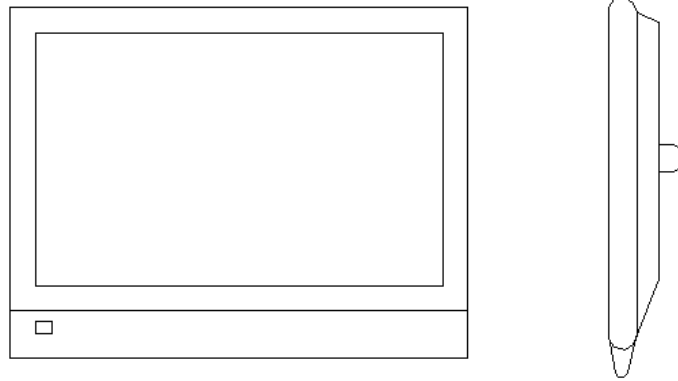

Screen mount (Qty. 1) – NOTE: Mount may appear and operate different then image below

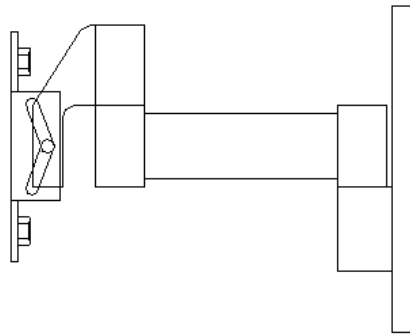

Control Box (Qty. 1)

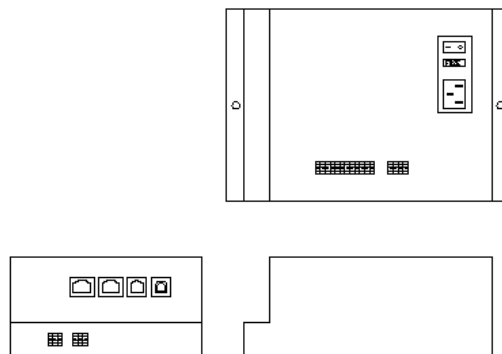

Touch screen beam (Qty. 1)



X-axis servo motor assembly and plate (Qty. 1)

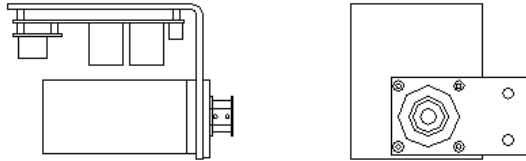

Y-axis servo motor assembly and plate (Qty. 1)

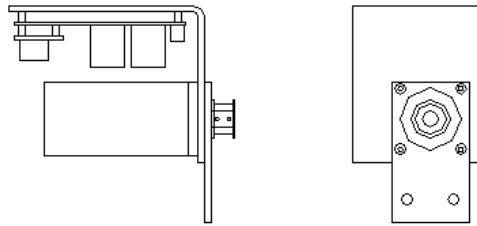

X and Y-axis communication cable (Qty. 2)

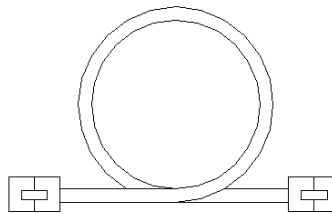

X and Y-axis power cable (Qty. 2)

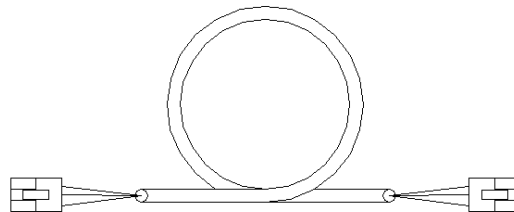

Controller power cord (Qty. 1)

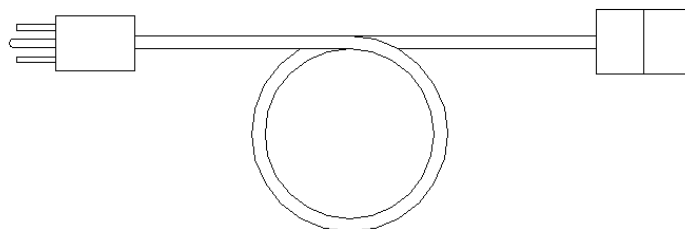

PC to Autopilot communication cable – USB A to USB B (Qty. 1)

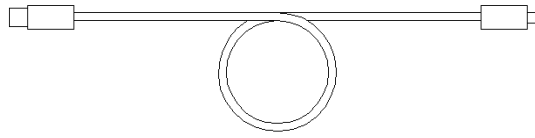

Pushbutton station (Qty. 1)

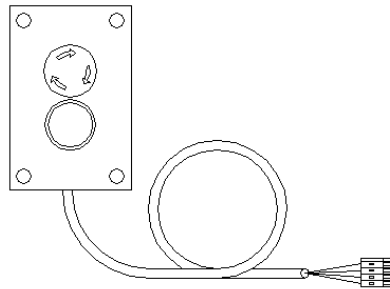

Innova communication cable with terminal block (Qty. 1)

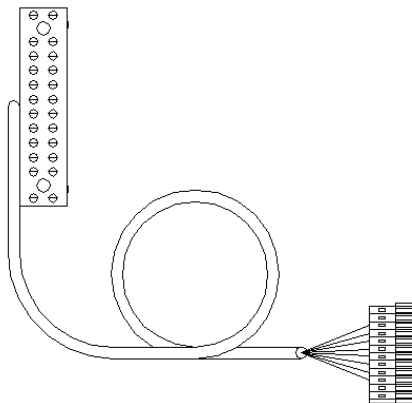

X-axis t-slotted beam (Qty. 1)

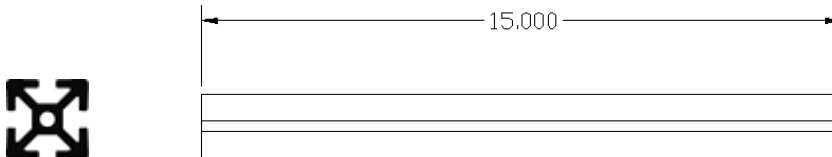

X-axis quick disconnect clamp (Qty. 2)

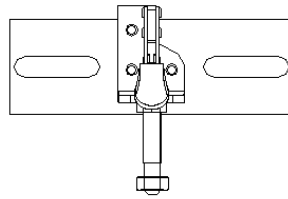

Y-axis quick disconnect clamp (Qty. 1)

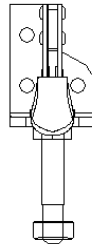

X-axis timing belt clamp plate (Qty. 2)

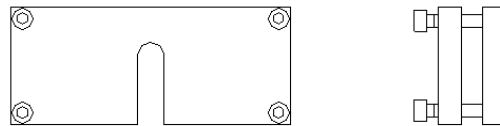

Y-axis timing belt clamp plate (Qty. 1)

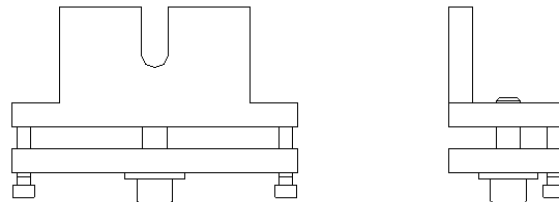

Carriage support cross block and plate (Qty. 1)

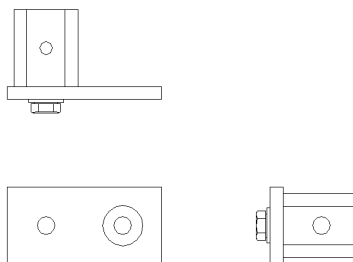

X-axis drive shaft (Qty. 1)



Large drive pulley (Qty. 1)

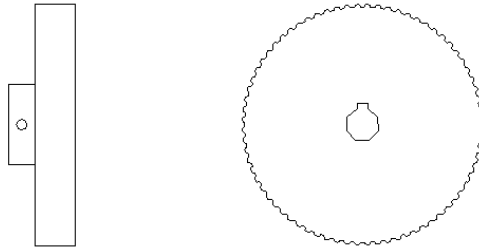

Medium drive pulley (Qty. 2)

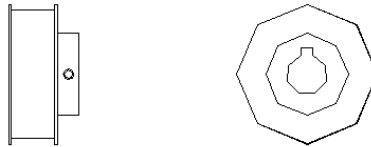

Y-axis drive pulley assembly (Qty. 1)

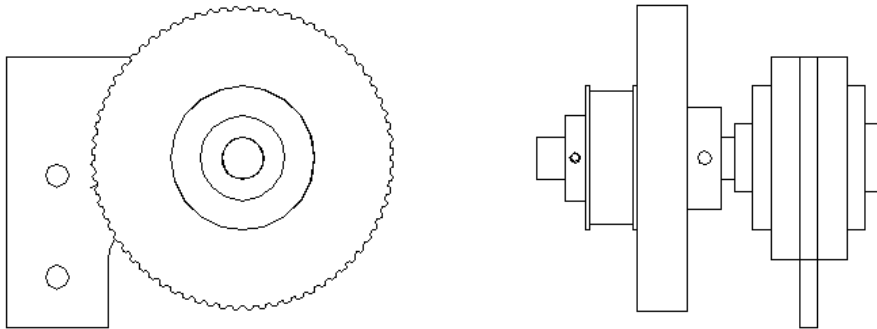

Y-axis idler pulley assembly (Qty. 1)

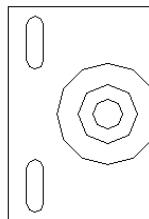

X-axis drive bearing assembly (Qty. 2)

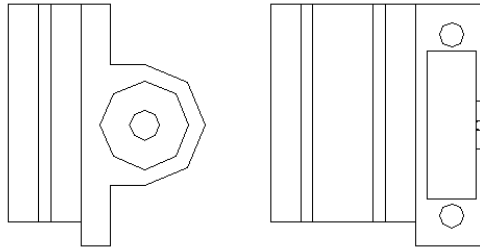

X-axis idler bearing assembly with guard (Qty. 2)

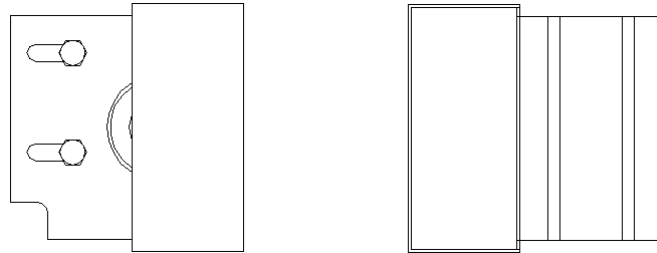

Y-axis motor guard (Qty. 1)

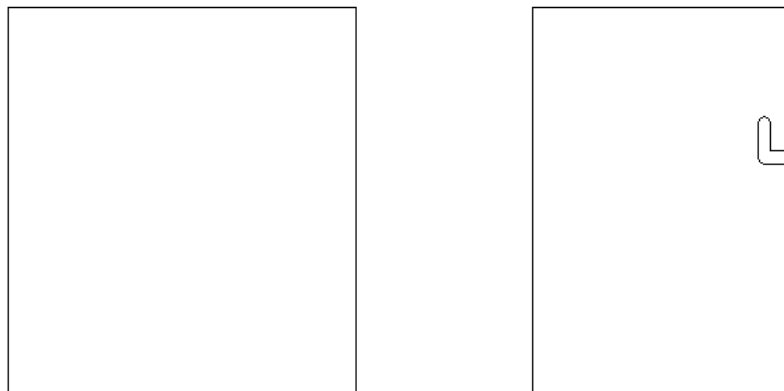

X-axis motor guard (Qty. 1)

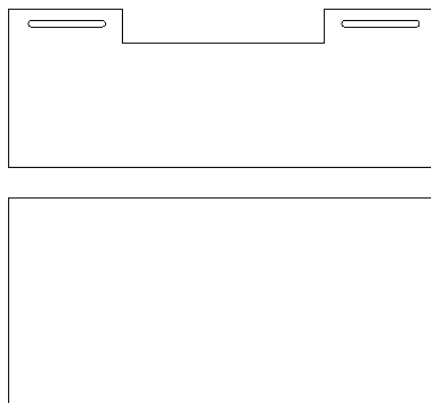

X-axis timing belt (Qty. 2)

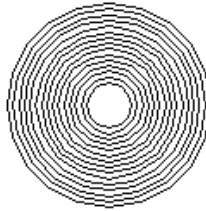

Y-axis timing belt (Qty. 1)

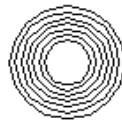

X and Y-axis main timing belt (Qty. 2)

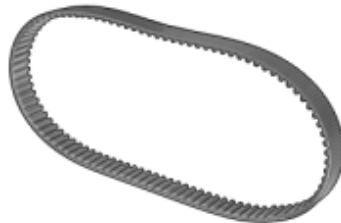

3/16 x 3/16 machine key (Qty. 3)

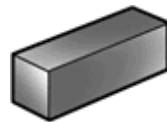

Twist lock cable tie holder (Qty. 2)



2.0 X-axis Assembly

NOTE: THESE INSTRUCTIONS ARE INTENDED FOR FRAMES ASSEMBLED WITH INSTRUCTION VERSION 19 OR NEWER. THE AUTOPILOT ASSEMBLY MANUAL DEMONSTRATES HOW TO INSTALL AN AUTOPILOT ON A 26" INNOVA. ASSEMBLY OF AN AUTOPILOT ON AN 18", 22", OR 32" INNOVA WILL DIFFER SLIGHTLY IN SOME STEPS. SEE SECTION 6.0 FOR AMENDMENTS TO INSTALLATION OF AN AUTOPILOT FOR 18" MACHINES. SEE SECTION 7.0 FOR AMENDMENTS TO INSTALLATION OF AN AUTOPILOT FOR 32" MACHINES.

Step 1: Install the X-axis servo motor assembly onto the 15" t-slotted beam using (2) 5/16 x 3/4" HEX bolts, (2) flat washers and (2) 5/16 T-nuts. Locate the plate in the center of the beam. **NOTE: MAKE SURE TO USE THE X-AXIS SERVO MOTOR ASSEMBLY. THE MOUNTING PLATE POSITION VARIES SLIGHTLY FROM BETWEEN THE X AND Y-AXIS.**

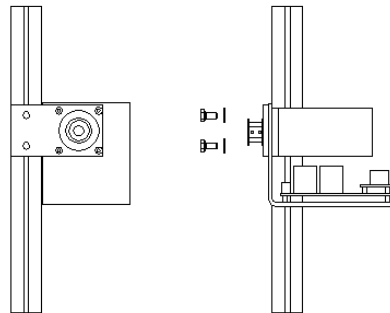

Step 2: **SEE SECTION 6.0 OR 7.0 FOR 18" OR 32" MACHINES.** Install the 15" X-axis t-slotted beam onto the right side of the frame in the seventh hole for a 26" machine or the ninth hole for a 22" machine measured from the rear of the machine at the top frame beam. Use (2) 5/16 x 2" HEX bolts, (2) flat washers and (2) 5/16 T-nuts.

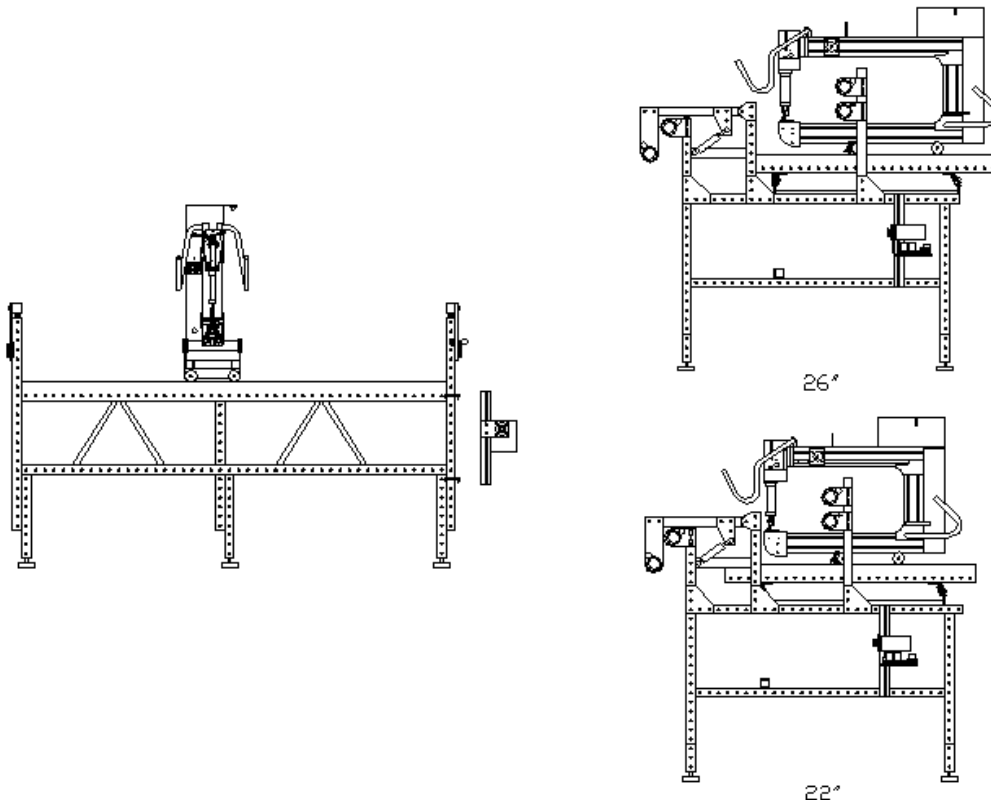

Step 3: Assemble (2) X-axis drive bearings assemblies with (2) medium drive pulleys and (1) large drive pulley. Make sure to place a key into the slot of the shaft for each of the pulleys. Leave the pulleys and bearing assemblies loose on the shaft. Drape the X-axis main timing belt onto the center of the shaft. **DO NOT TIGHTEN THE SET SCREWS.**

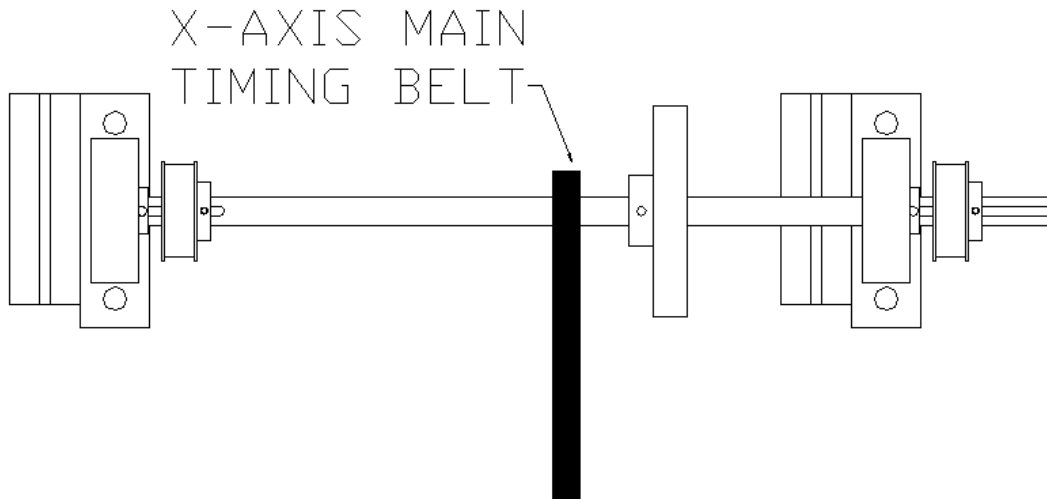

Step 4: **SEE SECTION 6.0 OR 7.0 FOR 18" OR 32" MACHINES.** With the X-axis main timing belt installed on the large pulley, install the X-axis drive shaft assembly onto the right side of the frame. For a 26" machine, attach the bearing assemblies at the 5th and 6th holes for the rear bearing and 16th and 17th hole for the front bearing, counting from the back of the top side tube. For a 22" machine, attach the bearing assemblies at the 7th and 8th holes for the rear bearing and 18th and 19th hole for the front bearing, counting from the back of the top side tube. Bolt the bearing assemblies using (4) 5/16 x 2" HEX bolts and (4) flat washers from the bottom up.

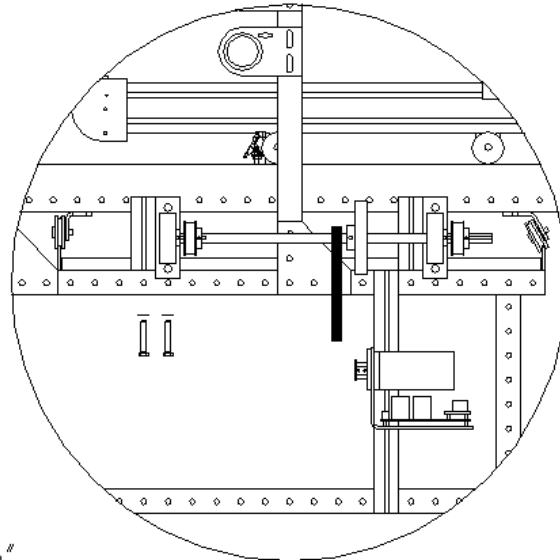
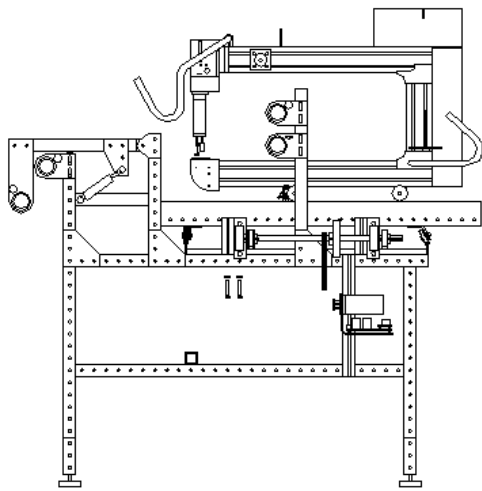

26"

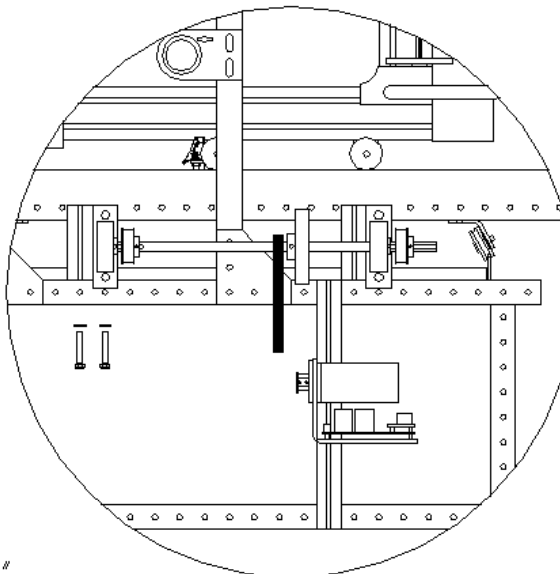
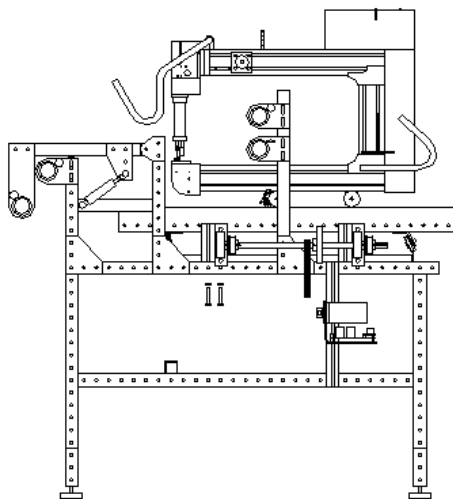

22"

Step 5: **SEE SECTION 6.0 OR 7.0 FOR 18" OR 32" MACHINES.** Install the (2) X-axis idler bearing assemblies with guards. For 26" machines, install them into the 5th and 6th holes for the rear assembly and 16th and 17th hole for the front assembly counting from the rear of the left side of the frame. For 22" machines, install them into the 7th and 8th holes for the rear assembly and 18th and 19th hole for the front assembly counting from the rear of the left side of the frame. Use (4) 5/16 x 2" HEX bolts and (4) flat washers. If the X-axis idler pulleys did not come with the guards installed, install the guards onto the assemblies using (4) 1/4" button head bolts and (4) flat washers.

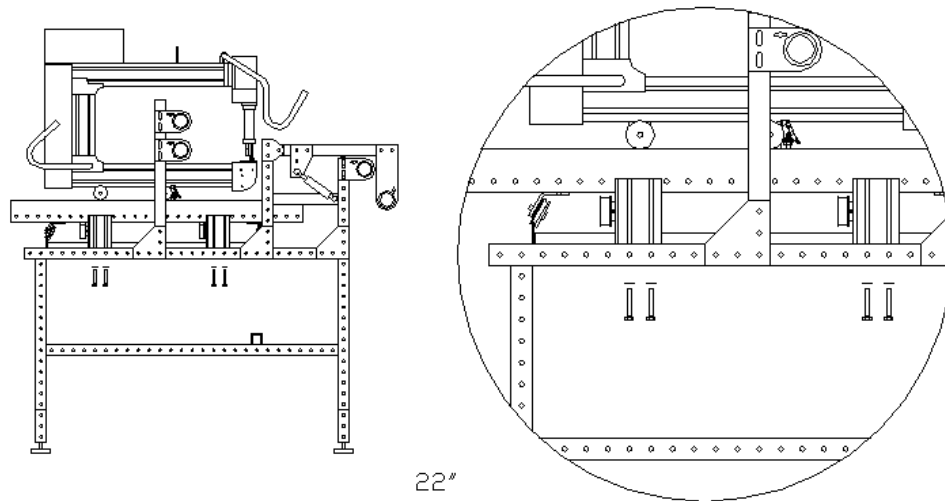
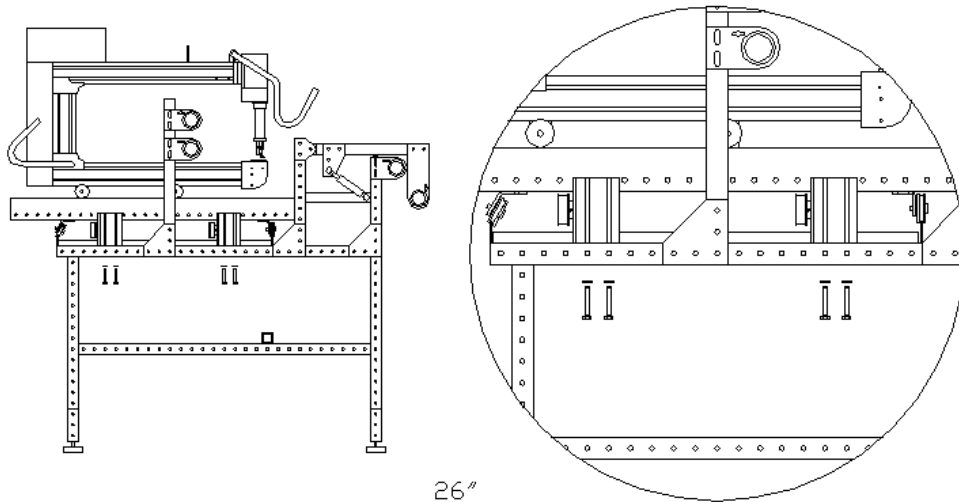

Step 6: Using (4) 5/16 x 2-3/4" HEX bolts, (4) flat washers and (4) nylon insert lock nuts, install the X-axis quick disconnect clamp brackets onto the left side of the lower carriage. Install the brackets so that the red handled clamp is aligned with the center of the idler pulleys on the left side of the machine.

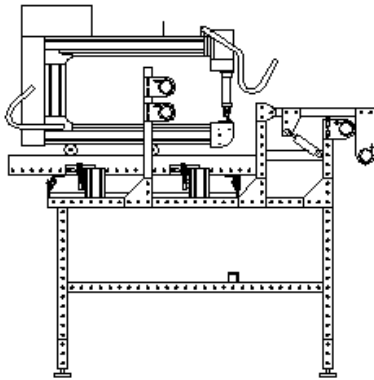

26"

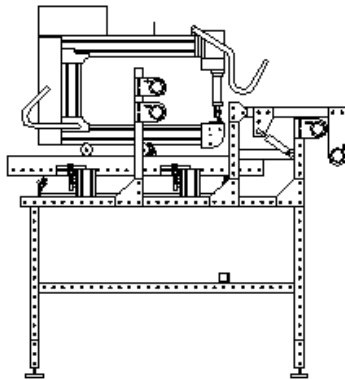

22"

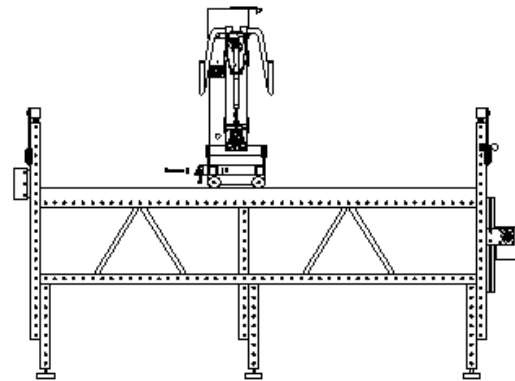

Step 7: Install the X-axis timing belt clamp onto the X-axis quick disconnect clamp. **NOTE: INSTALL THE CLAMP PLATE SO THAT THE SIDE WITH THE SMALL SLOT IS FACING UP.** Lift the red handle and check to make sure the clamp grips the plate assembly firmly. If the plate is loose, use a 7/16 wrench to tighten the hex nut on the bottom end of the clamp. **DO NOT OVERTIGHTEN OR THE CLAMP WILL BEND WHEN YOU ATTEMPT TO LOCK THE PLATE IN PLACE.**

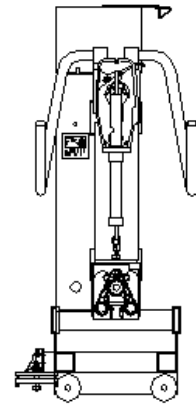
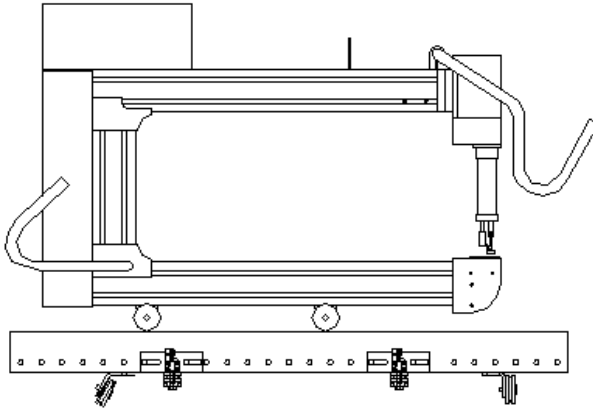

Step 8: Lay the white X-axis timing belts on the frame table with the teeth facing up. On the right side of the frame, pass the timing belt around the medium drive pulleys and secure to the belt clamp plates on the carriage. **NOTE: THE BELT WILL PASS UNDER THE CARRIAGE AND CONNECT TO THE CLAMP PLATES MOUNTED ON THE LEFT SIDE OF CARRIAGE.** Pass the left end of timing belt around the idler pulley assemblies and attach to the timing belt clamp plate. Tighten the timing belt clamp plate bolts and check to make sure that both timing belt clamp plates are equidistant from the left end. Jump the belt over the pulley on the drive end to align the clamp plates.

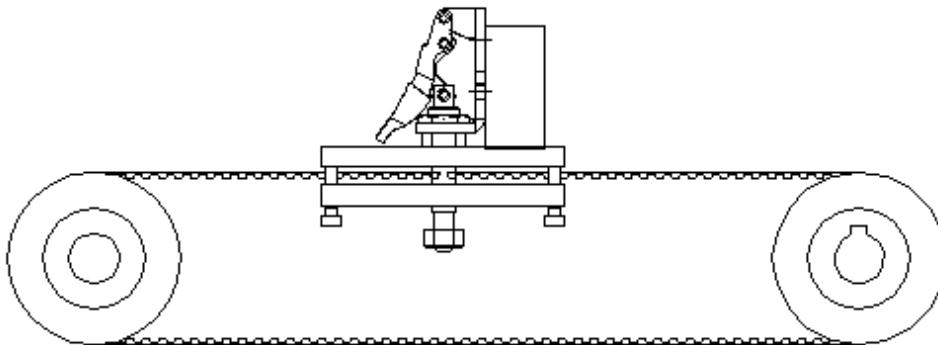

Step 9: Tighten the belts by loosening the (2) 5/16 HEX head bolts on the slotted idler bearing plates and pulling the plates out away from the frame.

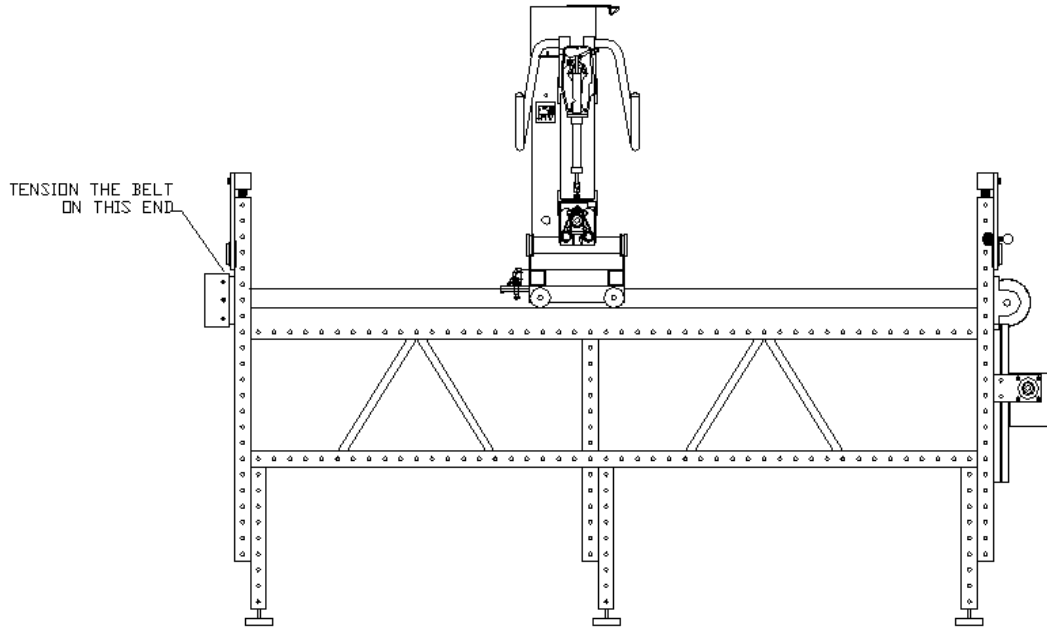

Step 10: Loosen the X-axis motor plate and slide the motor as high as possible on the slotted beam. Install the black X-axis main timing belt onto the motor pulley as well as the large drive pulley. Slide the large pulley on the shaft to align the large pulley and motor pulley. Tighten the set screws on the large pulley. Pull down on the motor plate to tension the black belt and tighten the (2) HEX bolts on the motor plate. **NOTE: THE BELT SHOULD BE TIGHTENED SO THAT RESISTANCE IS FELT WHEN YOU PRESS ON THE UNSUPPORTED SECTION OF THE BELT. THE BELT SHOULD BE TIGHT.**

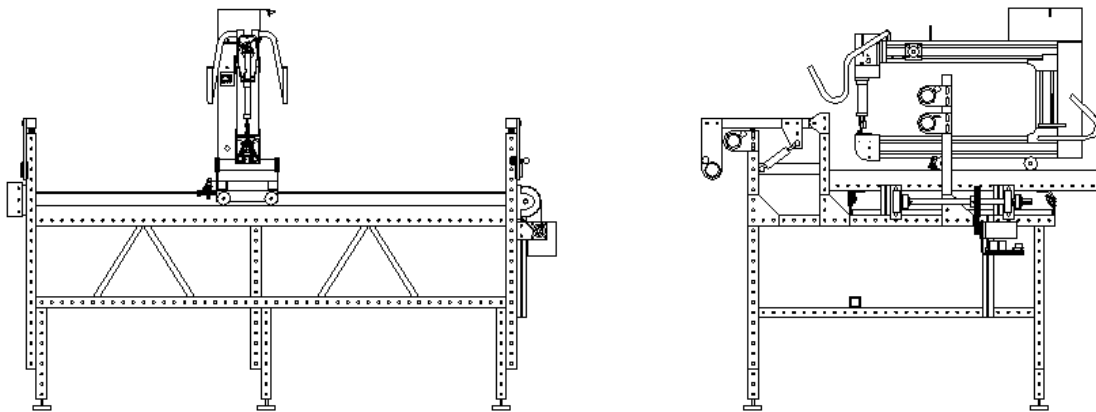

Step 11: Align the medium drive pulleys so the white X-axis timing belt is straight down the length of the frame. Ensure that all of the drive pulleys have keys in the keyways and tighten all (8) set screws, (4) on the medium drive pulleys and (4) on the bearing assemblies.

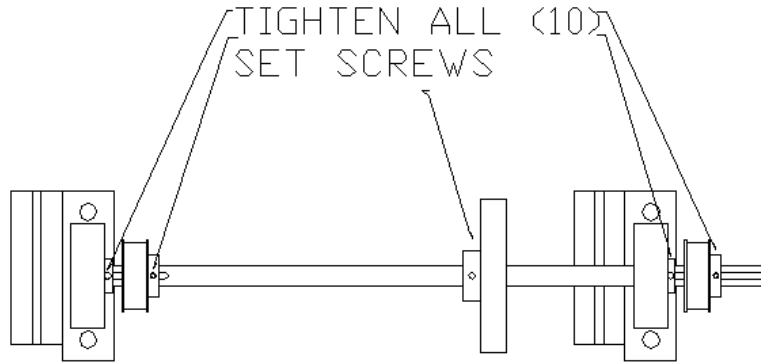

Step 12: Connect the communication cable and the power cable to the x-axis servo motor assembly. Leave the excess cable coiled up and out of the way for now.

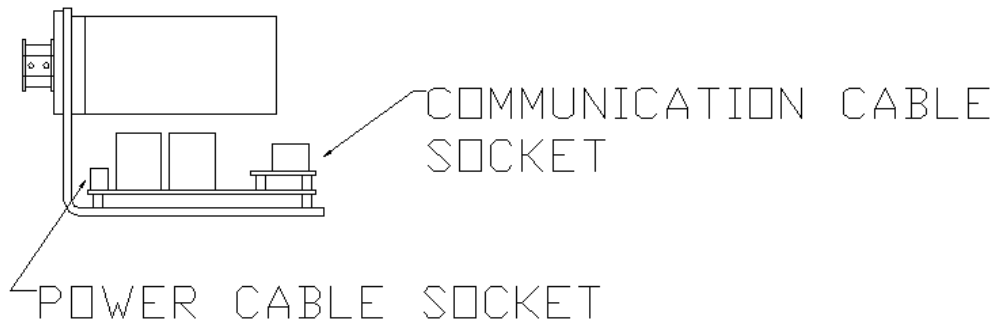

Step 13: Install the X-axis motor guard onto the right side of the frame. The slots in the top of the guard will align with the tapped holes in the t-slotted beams of the bearing assemblies. Use (2) 5/16 x 3/4" HEX bolts, (2) lock washers, and (2) flat washers to secure the guard.

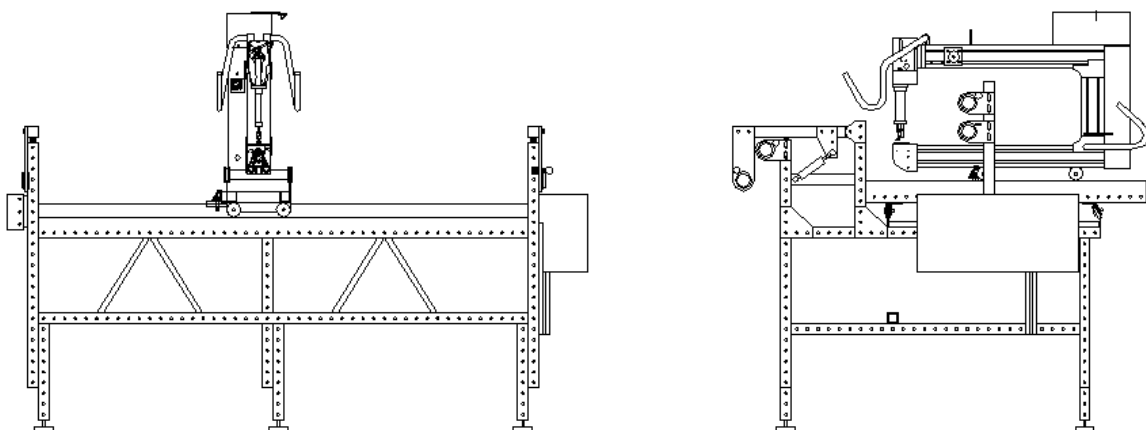

3.0 Y-Axis assembly

Step 1: In order to complete the installation of the Y-axis assembly onto an Innova, the front 6" t-slotted beam of the lower carriage must be located at the extreme front of the carriage. If the front beam is not in this position, please relocate it now.

Remove both hex head bolts on the either side of the carriage that hold the front t-slotted beam and remove the beam. Install (2) 5/16 t-nuts in the top of the beam, (1) 5/16 t-nut in the front face of the beam and (2) 5/16 t-nuts in the bottom of the beam. Re-install the beam in the first hole at the front of the carriage. Install the carriage support cross block into the front end of the left carriage rail and pass the original bolt holding the t-slotted beam through it and secure. Using a 5/16 x 3/4" hex head bolt and flat washer attach the cross block plate to the front face of the t-slotted beam. Make sure to tighten both sides of the 6" t-slotted beam to either lower carriage rail.

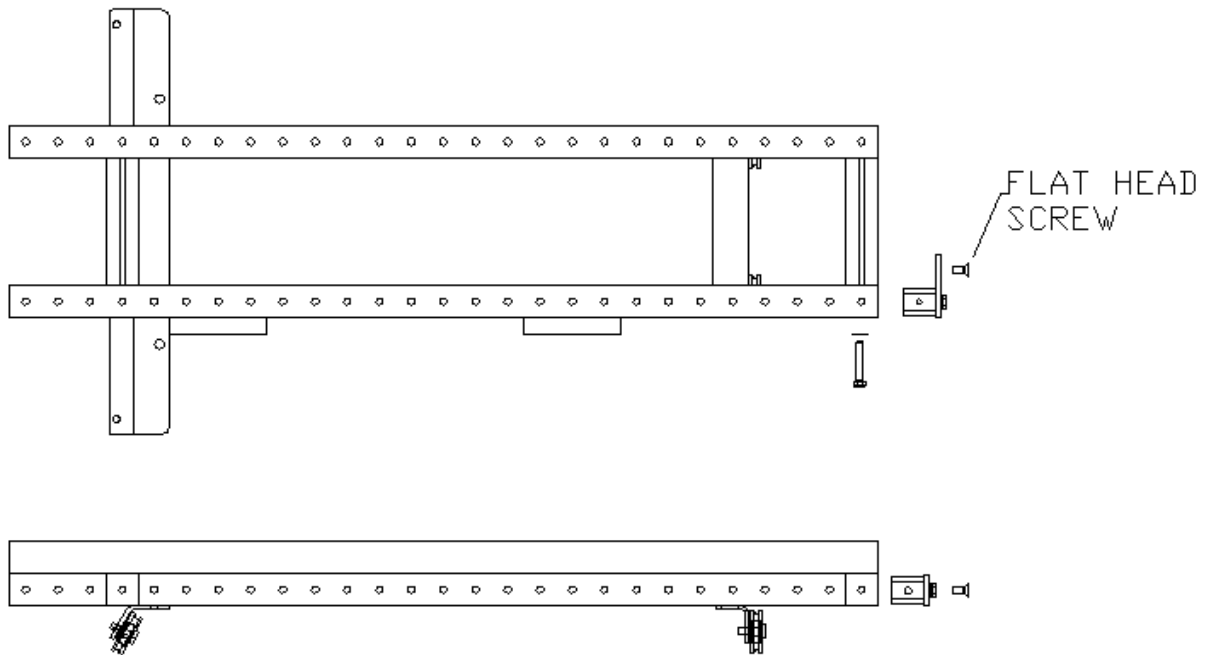

Step 2: Install the Y-axis drive pulley assembly to lower side of the front t-slotted beam using (2) 5/16 x 3/4" hex head bolts and flat washers. Adjust the assembly so the large diameter pulley is flush to outside of the lower carriage right rail. Tighten the bolts.

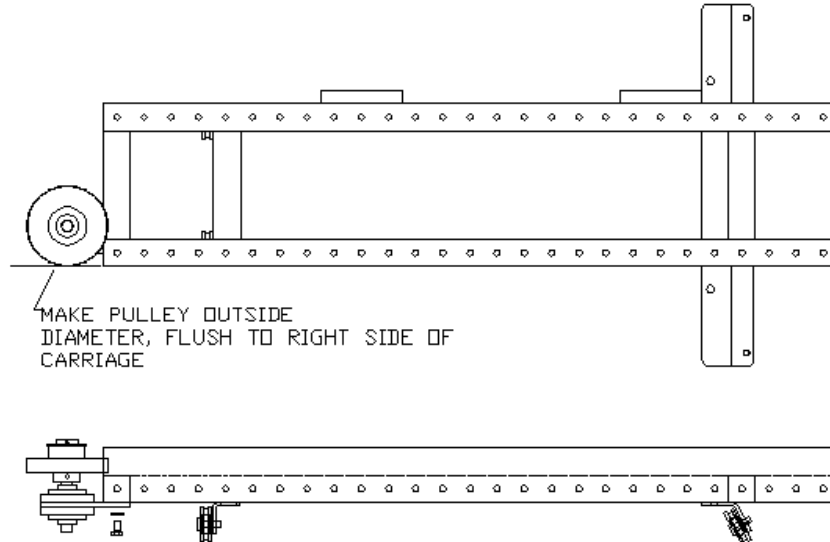

Step 3: Install the Y-axis servo motor assembly onto the top side of the front t-slotted beam using (2) 5/16 x 3/4" hex head bolts, (2) flat washers and (2) 5/16 t-nuts previously installed in the beam.

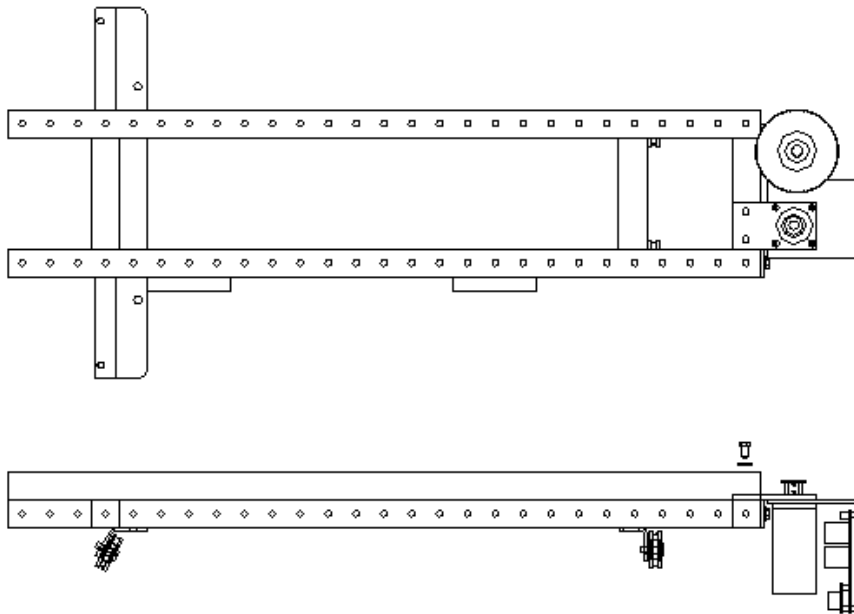

Step 4: Install the black Y-axis main timing belt onto the motor pulley and large drive pulley. Tension the belt by loosening the motor plate screws and pulling the motor away from the large pulley. Tighten the bolts **NOTE: THE BELT SHOULD BE TIGHTENED SO THAT RESISTANCE IS FELT WHEN YOU PRESS ON THE UNSUPPORTED SECTION OF THE BELT.**

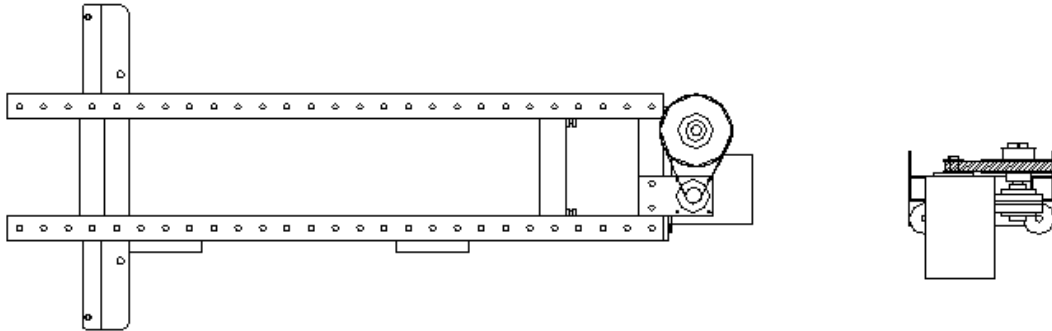

Step 5: **SEE SECTION 7.0 FOR 32" MACHINES.** Install the Y-axis idler pulley onto the inside of the right carriage rail directly in front of the lower carriage rear wheel assembly using (2) 5/16 x 2-3/4" hex head bolt, (4) flat washers and (2) nylon insert lock nuts.

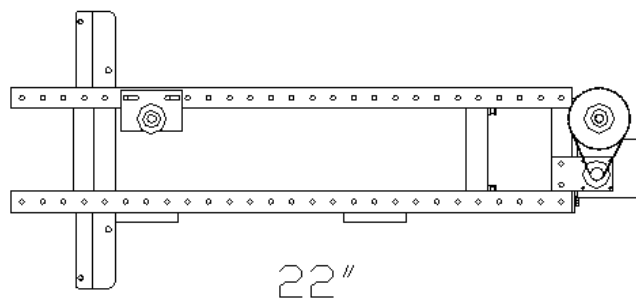
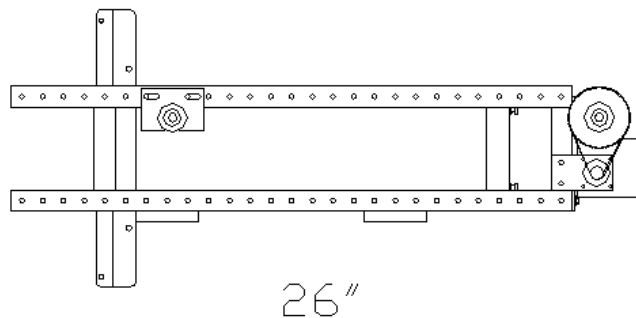

Step 6: Install the Y-axis quick disconnect clamp onto right front wheel beam of the Innova using (2) 8-32 x 1/2" socket head bolts and (2) 8-32 t-nuts. See the diagram below for correct orientation.

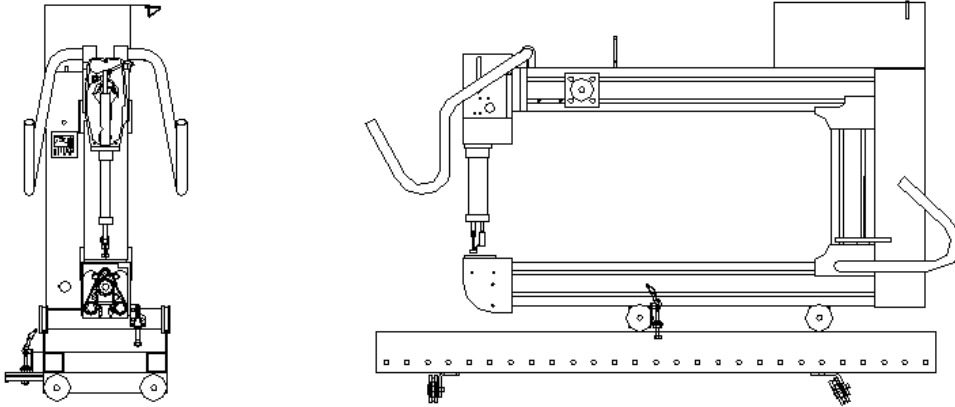

Step 7: Install the Y-axis timing belt clamp plate onto the quick disconnect clamp. Be sure to follow the orientation in the diagram below.

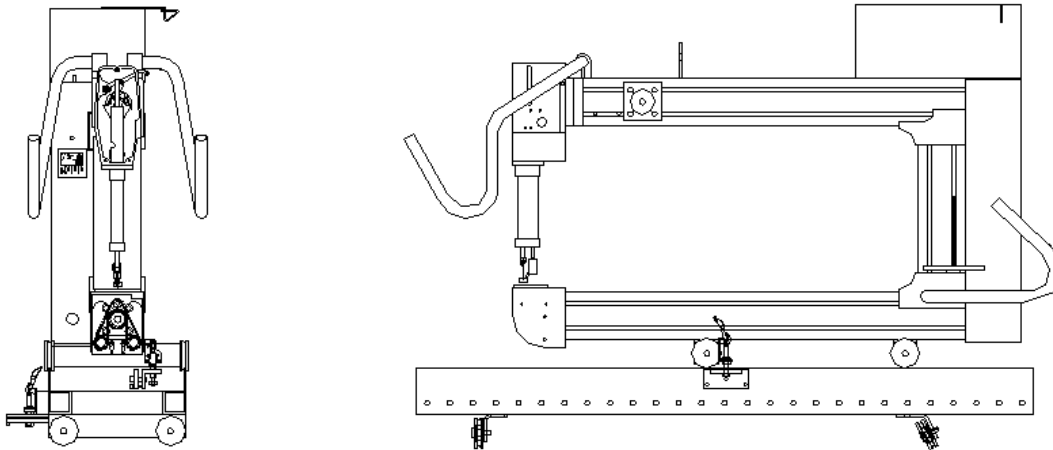

Step 8: Install the white Y-axis timing belt onto the front medium drive pulley and the rear idler pulley. Install the open ends of the belt as high as possible in the clamp plate and tighten the (2) #8 bolts and the (1) ¼” bolt in the center. **NOTE: THE CLAMP PLATE MUST BE INSTALLED ON THE LEFT SIDE OF THE WHITE TIMING BELT LOOP. TO CHECK FOR PROPER INSTALLATION, THE INNOVA SHOULD MOVE TOWARD THE FRONT WHEN THE LARGE PULLEY IS TURNED COUNTER-CLOCKWISE WHEN VIEWED FACING FROM THE TOP LOOKING DOWN.**

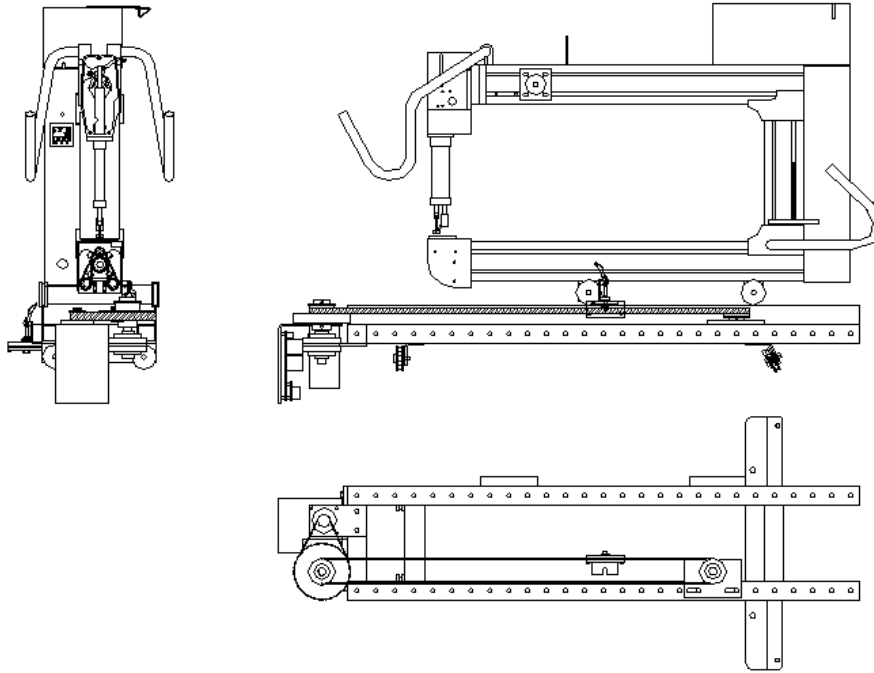

Step 9: Tighten the white belt by pulling the idler pulley assembly toward the rear of the carriage and tightening the (2) hex head bolts.

Step 10: Connect the communication cable and the power cable to the y-axis servo motor assembly.

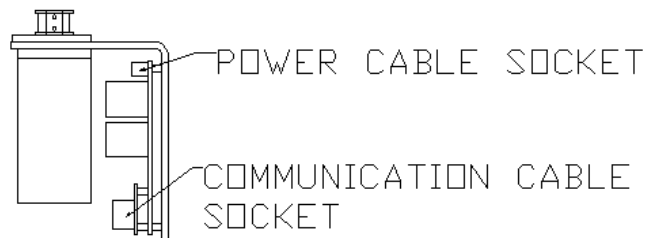

Step 11: Wire tie the communication cable and the power cable to carriage as shown below.

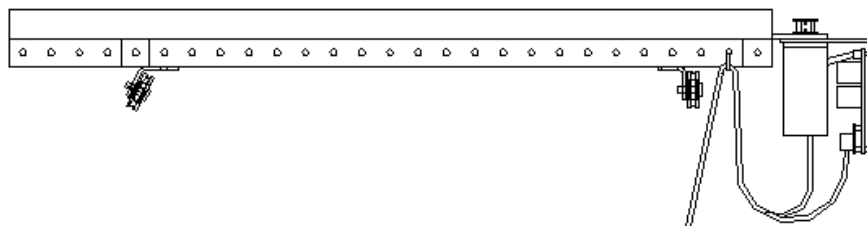

Step 12: Install the Y-axis motor guard onto the front of the lower carriage. Hold the open side of the guard assembly vertically and bring the guard up into the Y-axis servo motor assembly. Rotate the guard up and over the pulley and motor assemblies and fit the slots onto the bolts. **DO NOT FORCE THE GUARD OVER THE MOTOR ASSEMBLY. TAKE CARE WHEN INSTALLING SO THAT THE MOTOR ASSEMBLY AND CABLING IS NOT DAMAGED.**

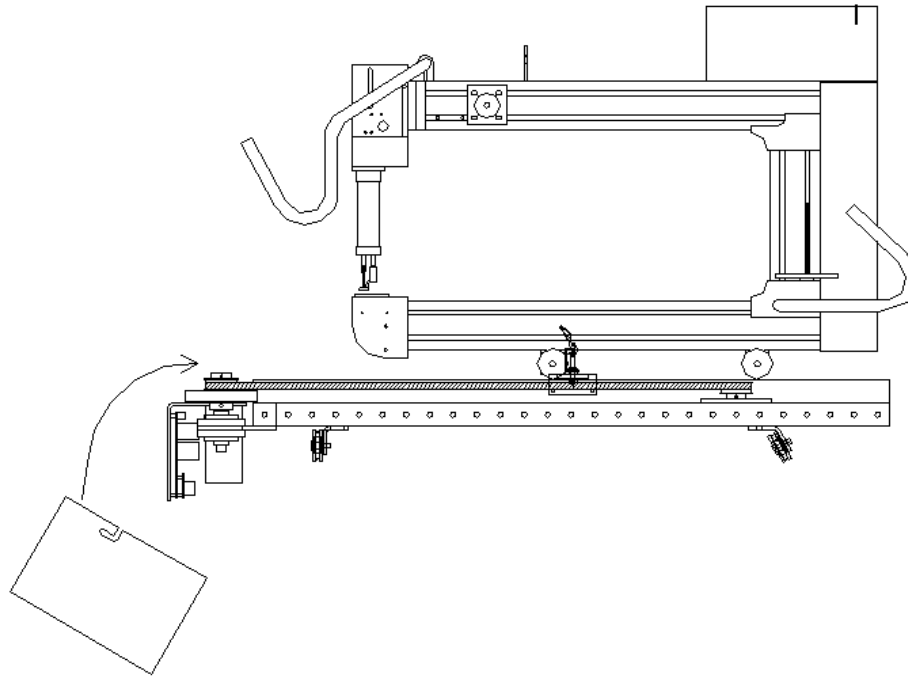

4.0 Wiring

Step 1: Loosen, but do not remove, the (8) screws on the top motor cover and the (7) screws on the rear electronics cover of the Innova. Remove the top motor and rear cover and set aside. Take care not to scratch the covers.

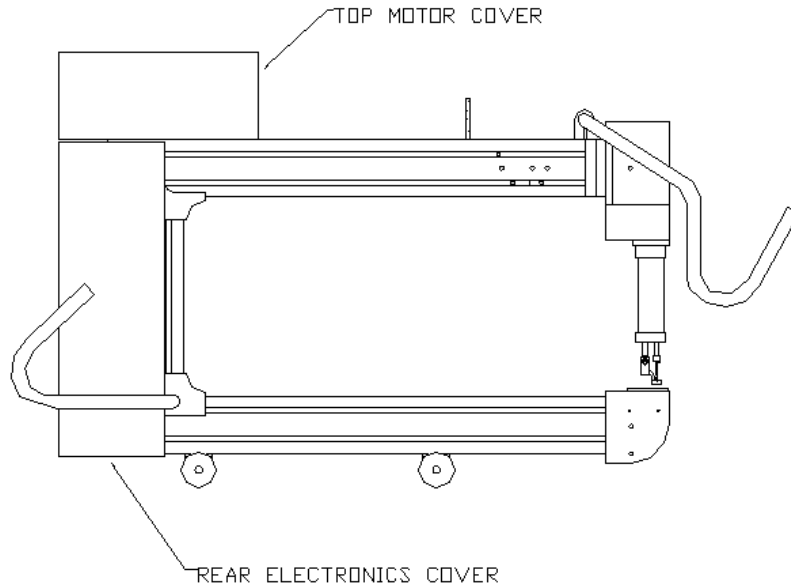

Step 2: **NOTE, THIS STEP IS FOR STANDARD STITCH AND PRO-STITCH REGULATED MACHINES ONLY, SKIP TO STEP 3 FOR LIGHTNING STITCH EQUIPPED MACHINES.** Locate the Innova communication cable and terminal block. If double-sided tape is applied to the terminal block, remove the backing and attach the block in the position noted below. When attaching the terminal block to the machine, be sure that the communication cable is on the left side of the block and the unused, “open” terminals are facing to the right side of the machine. **NOTE: IF DOUBLE-SIDED TAPE IS NOT PROVIDED, PLEASE USE 5-MINUTE EPOXY TO ATTACH THE TERMINAL BLOCK TO THE MACHINE. EPOXY PROVIDES A STRONGER BOND AND IS THE PREFERRED METHOD WHEN AUTOPILOTS ARE ASSEMBLED AT THE FACTORY. FOR PACKAGING AND SHIPPING CONCERNS, 5-MINUTE EPOXY IS NOT INCLUDED WITH THE KIT.**

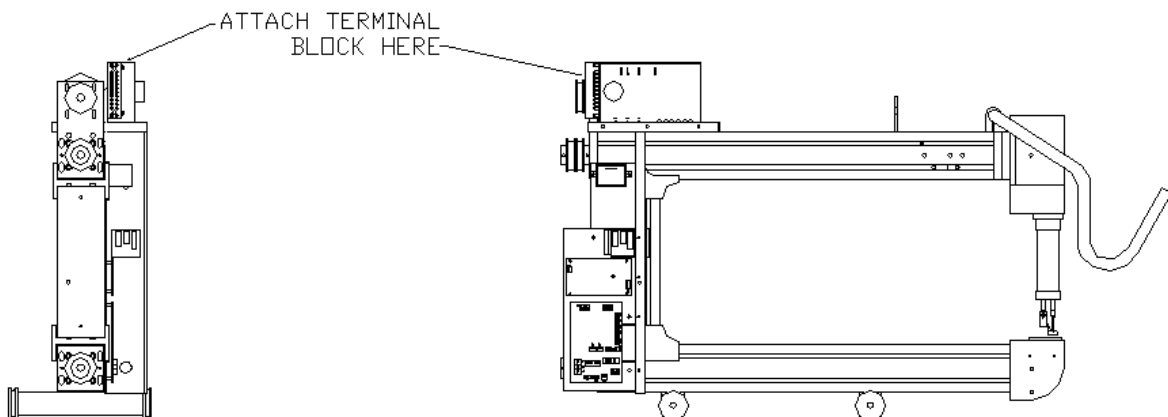

Step 3: Following the wiring diagram provided in the rear of this manual:

FOR STANDARD AND PRO-STITCH REGULATED MACHINES: Connect the labeled terminal block locations to the corresponding PLC green terminals with the provided 18 AWG wire. Additionally, disconnect the (2) black 5-wire stitch regulator encoder cables from the rear of the PLC and connect them to the new gray terminal block. Make sure to connect the encoder that is located at the rear of the lower carriage to the terminals marked X and attach the encoder located in front of the Innova main ON/OFF switch to the terminals labeled Y.

FOR LIGHTNING STITCH MACHINES: If present, remove the terminal block from the communication cable, and wire the cable to the Lightning board as illustrated in the wiring diagrams at the back of the manual.

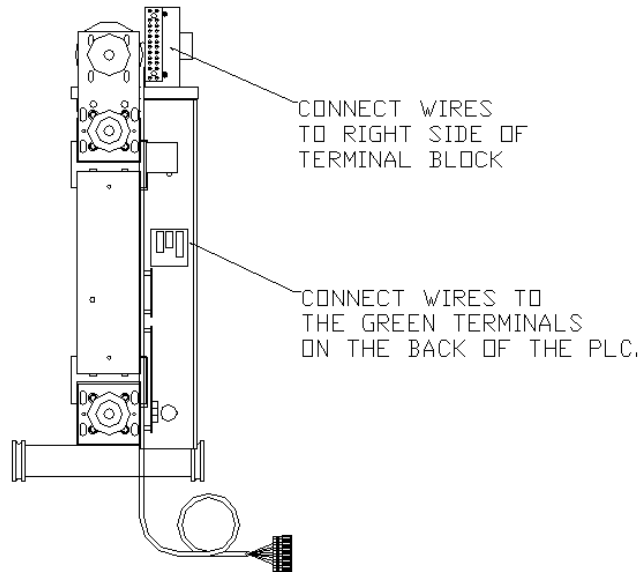

Step 4: Using the provided nylon ties, secure the communication cable and 18 AWG wires to the existing Innova wiring harness. Be sure to route and secure all of the wires so that they do not come in contact with any of the moving pulleys of belts on the machine.

Step 5: Nylon tie the communication cable to the bottom electronics cover plate. Use at least (2) nylon ties to secure the cable through the same holes to which the encoders and power cable are attached.

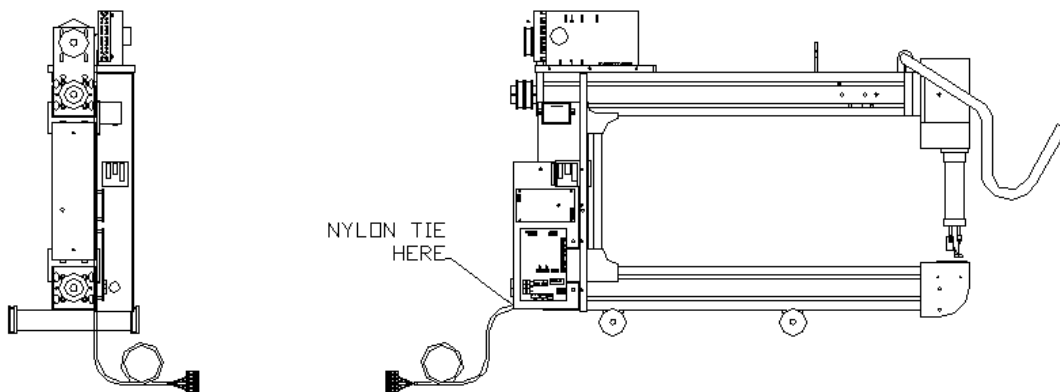

Step 6: Secure the communication cable to the black plastic wire tie mount on the rear of the Innova carriage. Provide enough slack for the machine to move freely and completely from the front to the back.

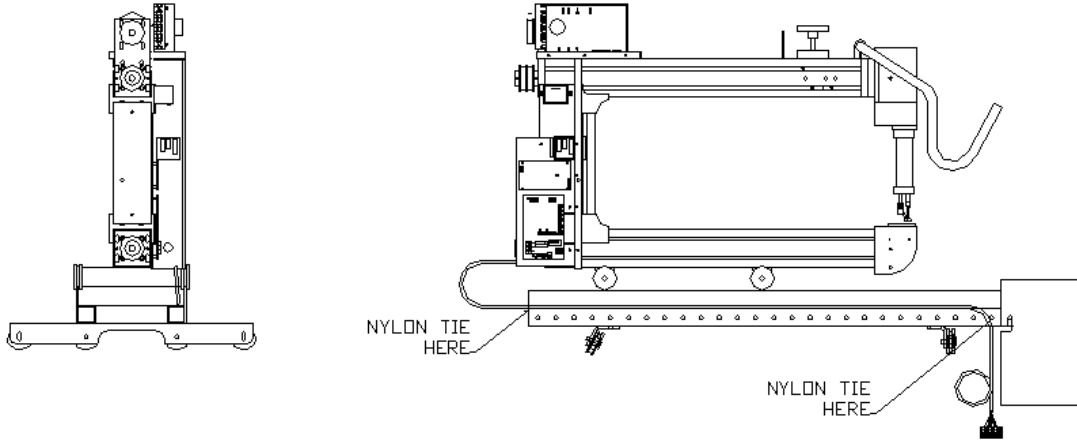

Step 7: MAKE A CHOICE:

CABLES LOCATED AT THE REAR OF THE MACHINE: Wire tie the communication cable to the power cord.

CABLES LOCATED UNDER THE QUILT AT THE FRONT OF THE MACHINE: Route and wire tie the communication cable along the inside to the lower carriage rail and the front of the carriage underneath the Y-axis motor guard. Make sure the communication cable does not rub on the pulleys and belts located at the front of the carriage. Nylon tie the cable to the hole provided in the left side of the motor guard.

5.0 Final Assembly

Step 1: **SEE SECTION 6.0 OR 7.0 FOR 18" OR 32" MACHINES.** Attach the touch screen beam to the left or right side of the frame in the location illustrated below. Use (3) 1/4" x 2" socket head cap screws, (3) flat washers, (3) lock washers and (3) 1/4" t-nuts.

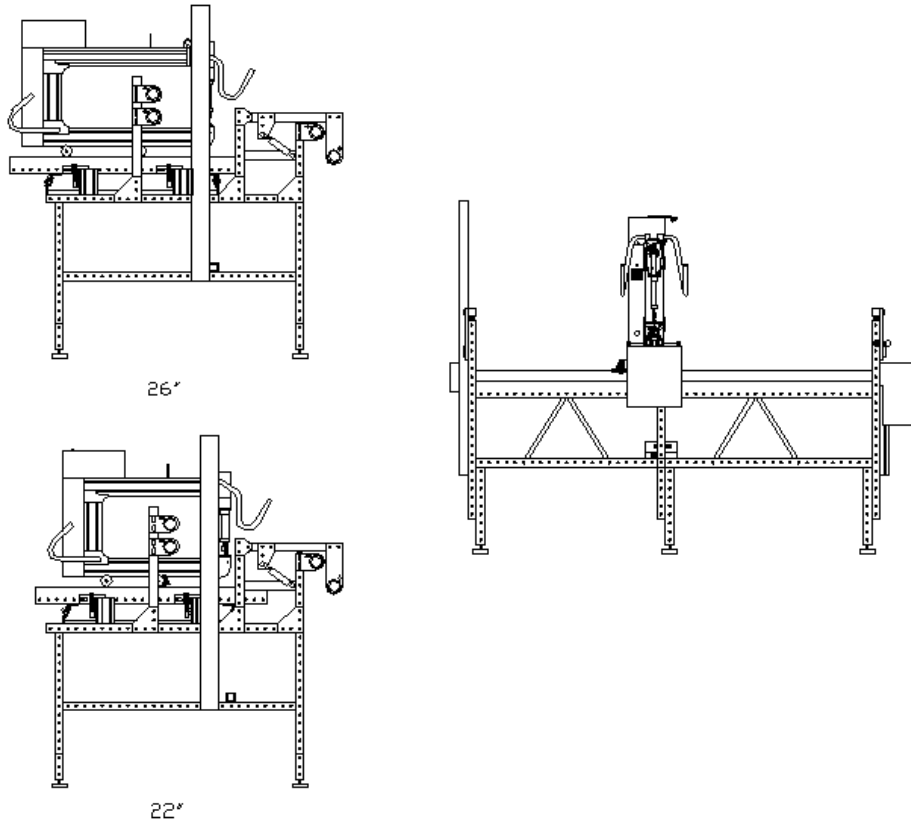

Step 2: Remove the front cover of the pushbutton station and install it onto the touch screen beam.

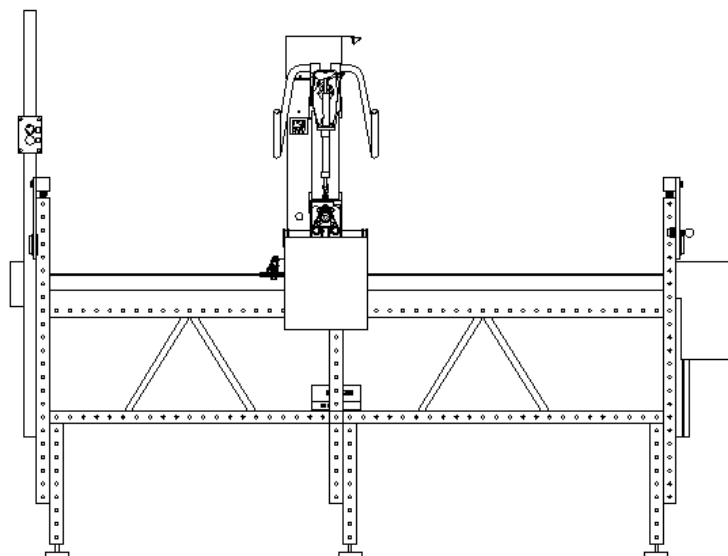

Step 3: Install the touch screen mount onto the beam. Adjust to an appropriate height for the user.

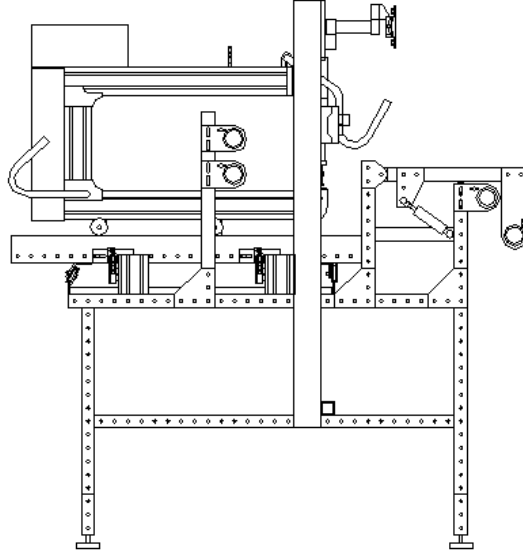

Step 4: Install the computer onto the mount and secure it using the provided hardware.

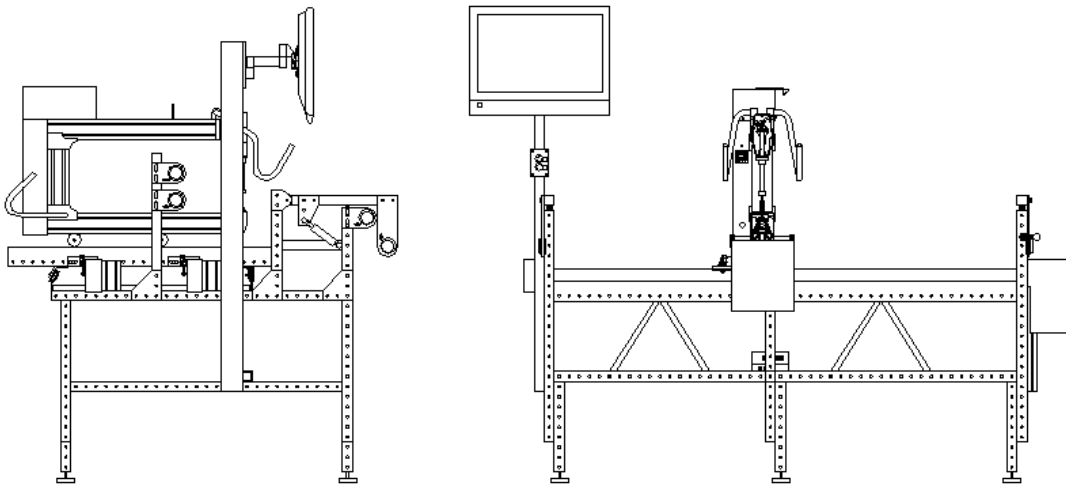

Step 5: Install the controller onto the lower cross beam of the center frame leg assembly. Position the controller so that the sockets face towards the front of the machine. Use (2) 10-32 x 2" bolts, (2) flat washers and (2) nylon insert lock nuts.

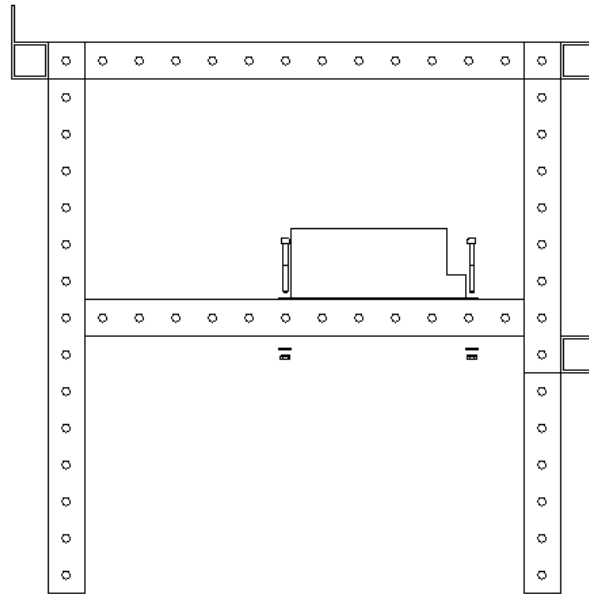

Step 6: Familiarize yourself with the terminals located on the front of the control box. Connect the power cord to the corresponding terminal.

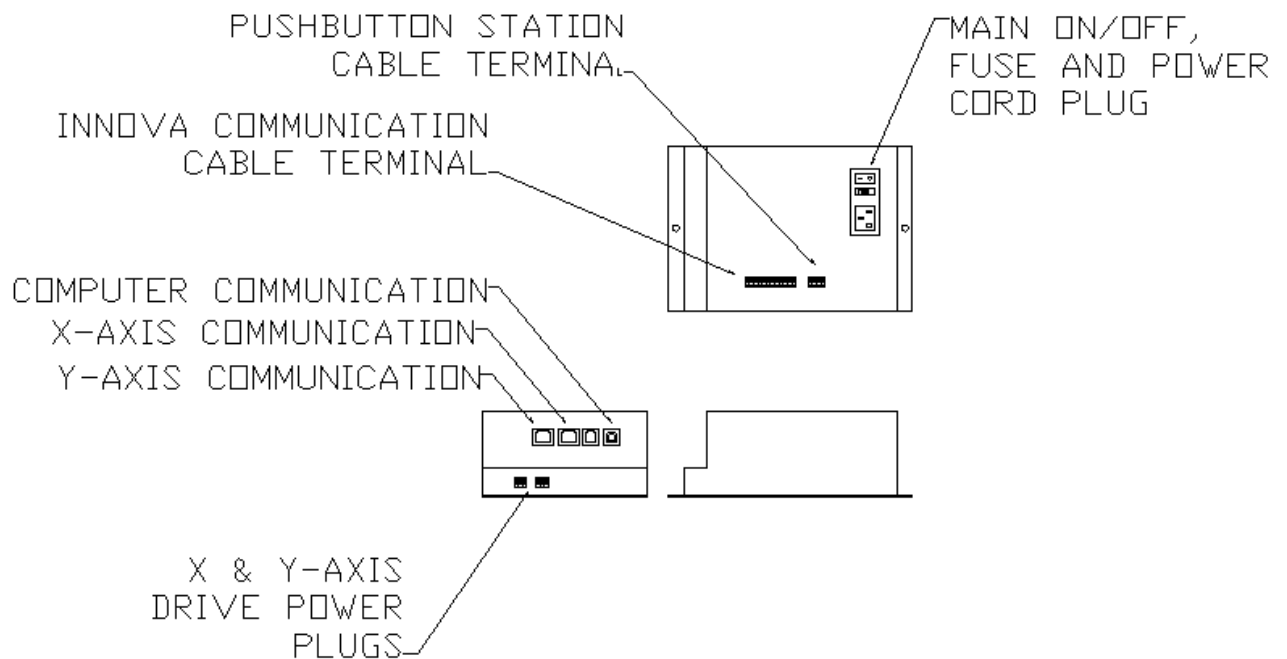

Step 7: Connect the Innova communication cable and the pushbutton station cable to the control box.

Step 8: Locate the X and Y-axis power and communication cables previously wired to the motor assemblies. Route and wire tie the power and communication cable from the X and Y motor assemblies to the control box. Connect them to the control box. **NOTE: MAKE SURE NOT TO BEND THE CABLES TOO SHARPLY AND DO NOT OVER-TIGHTEN THE WIRE TIES. FAILURE TO DO SO WILL CAUSE STRAIN ON THE CABLES AND PREMATURE FAILURE.**

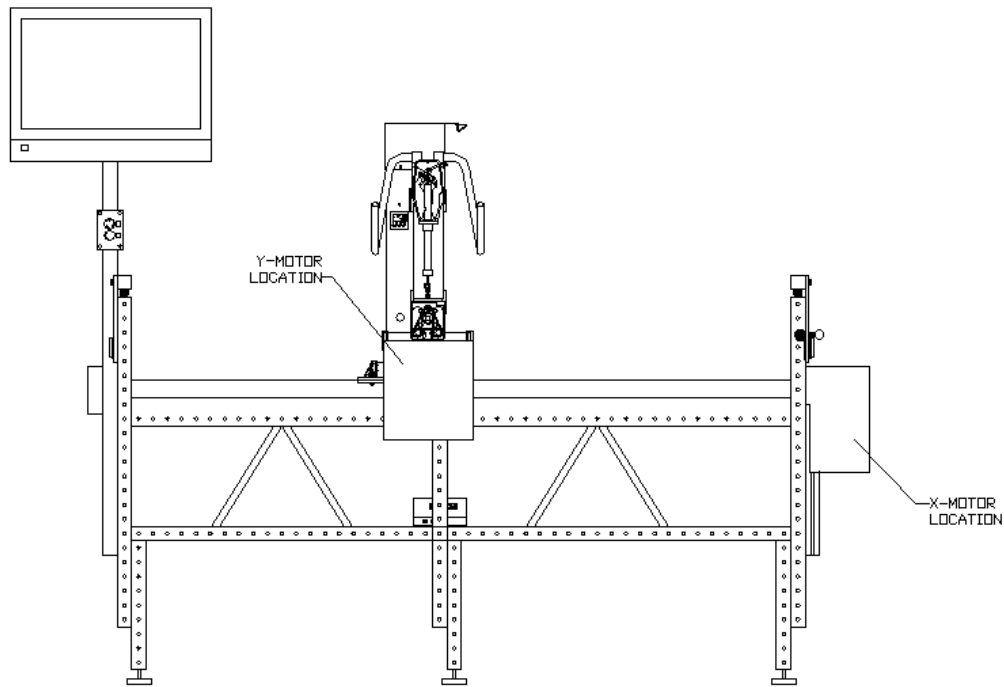

Step 9: Locate the computer power cord and the PC to Autopilot communication cable. Attach the power cord to the rear of the computer. Attach the USB end of the PC to Autopilot communication cable to one of the available USB ports on the rear of the computer. Using the (2) provided twist-lock wire tie mounts, route and wire tie the PC cables and pushbutton station cable to the touch screen beam.

Step 10: Connect the PC to Autopilot communication cable phone plug end into the control box PC communication terminal.

Step 11: Confirm that the machine has a free range of motion and is not limited by any cables. Adjust the length of or re-route the cables if necessary.

Step 12: Coil up and secure any excess cabling to the frame using the provided wire ties. **NOTE: FAILURE TO DO SO MAY CAUSE A TRIPPING HAZARD AND/OR MACHINE DAMAGE.**

Step 13: Connect the PC and the Autopilot transformer power cords to an available 110V outlet (220V – single phase is acceptable as well).

6.0 18" Autopilot assembly modifications

SECTION 2.0 MODIFICATIONS FOR 18" ASSEMBLY

Step 2: **SEE SECTION 6.0 FOR 18" MACHINES.** Install the 15" X-axis t-slotted beam onto the right side of the frame in the eleventh hole of the top frame beam from the rear of the machine. Use (2) 5/16 x 2" HEX bolts, (2) flat washers and (2) 5/16 T-nuts.

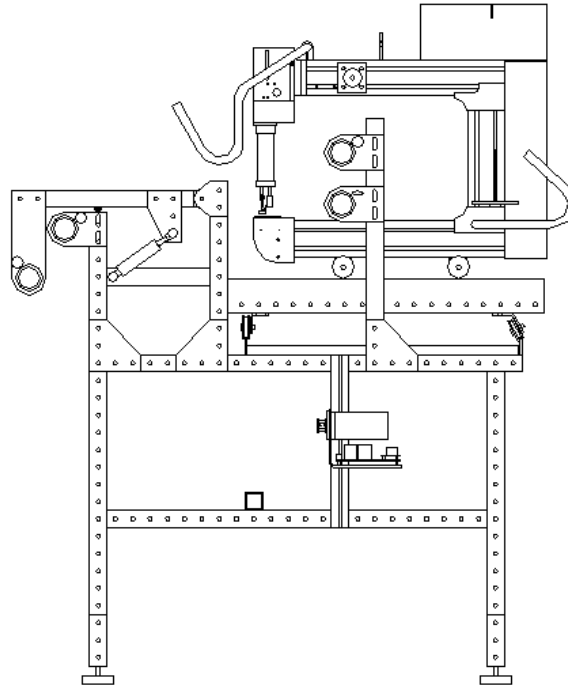

Step 4: Reverse the 5 hole gusset plate on the right side of the frame as illustrated below. Install the X-axis drive shaft assembly onto the right side of the frame. Attach the bearing assemblies at the 5th and 6th and 14th and 15th hole, from the back of the top side tube. Bolt the bearing assemblies using (4) 5/16 x 2" HEX bolts and (4) flat washers from the bottom up.

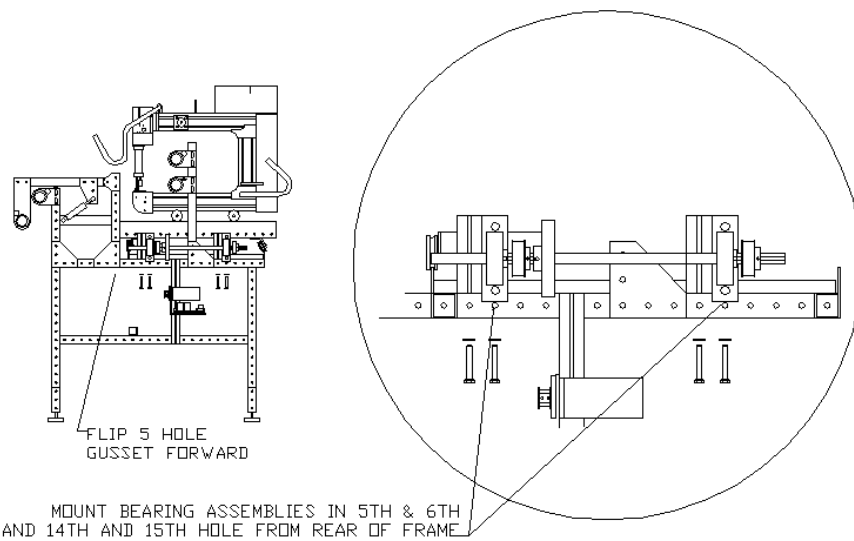

Step 5: Reverse one of the X-axis idler bearing assemblies to look like the assembly on the right in the magnified view. Install the (2) X-axis idler bearing assemblies with guards into the 5th and 6th holes for the rear assembly and the 11th and 12th hole for the front assembly counting from the rear of the left side of the frame. Use (4) 5/16 x 2" HEX bolts and (4) flat washers.

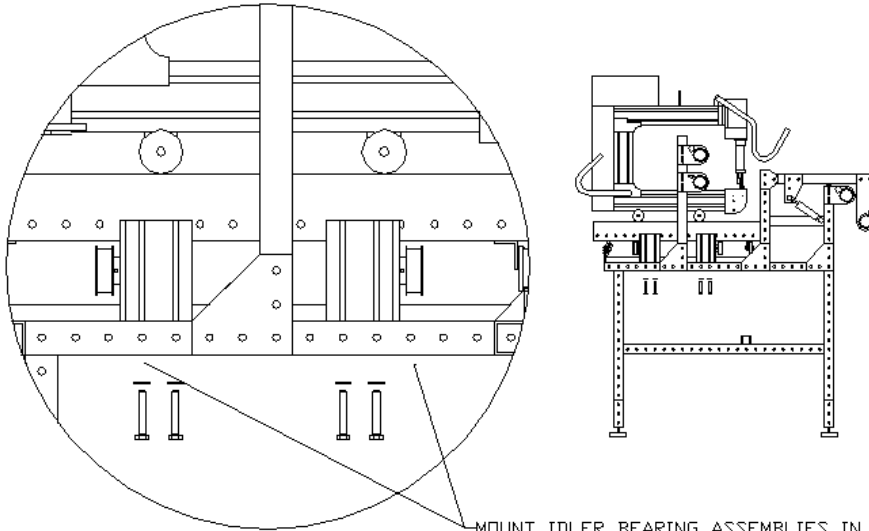

MOUNT IDLER BEARING ASSEMBLIES IN 5TH & 6TH AND 11TH & 12TH HOLE FROM REAR OF FRAME. BE SURE TO REVERSE FRONT IDLER BEARING ASSEMBLY AS ILLUSTRATED.

SECTION 5.0 MODIFICATIONS FOR 18" AUTOPILOT

Step 1: Attach the 52" touchscreen beam to the left or right side of the frame in the location illustrated below. Use (2) 1-1/2 x 3 spacer blocks, (3) 1/4" x 3-1/2" socket head cap screws, (3) flat washers, (3) lock washers and (3) 1/4" t-nuts.

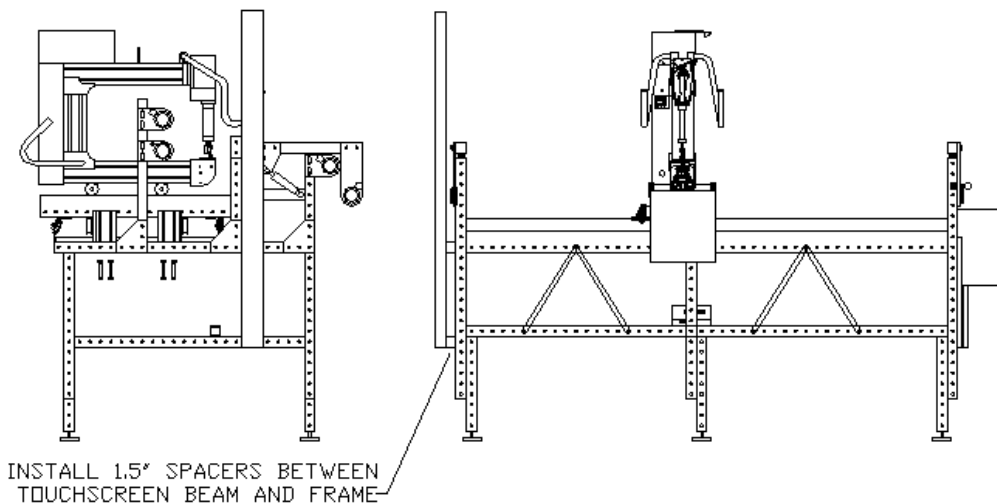

7.0 32" Autopilot assembly modifications

SECTION 2.0 MODIFICATIONS FOR 32" ASSEMBLY

Step 2: **SEE SECTION 6.0 FOR 18" MACHINES.** Install the 15" X-axis t-slotted beam onto the right side of the frame in the eleventh hole of the top frame beam from the rear of the machine. Use (2) 5/16 x 2" HEX bolts, (2) flat washers and (2) 5/16 T-nuts.

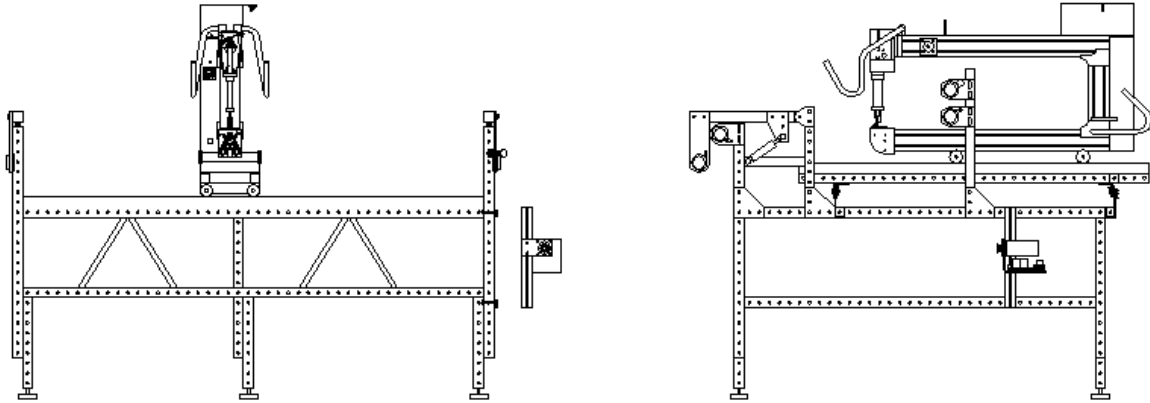

Step 4: Install the X-axis drive shaft assembly onto the right side of the frame. Attach the bearing assemblies at the 9th and 10th and 20th and 21st hole, from the back of the top side tube. Bolt the bearing assemblies using (4) 5/16 x 2" HEX bolts and (4) flat washers from the bottom up.

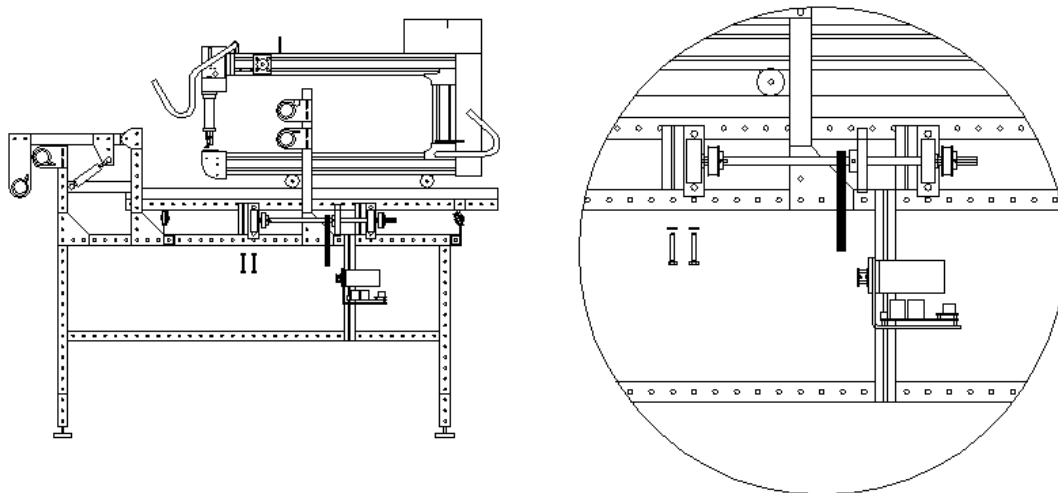

Step 5: Install the (2) X-axis idler bearing assemblies with guards into the 9th and 10th holes for the rear assembly and the 20th and 21st hole for the front assembly counting from the rear of the left side of the frame. Use (4) 5/16 x 2" HEX bolts and (4) flat washers.

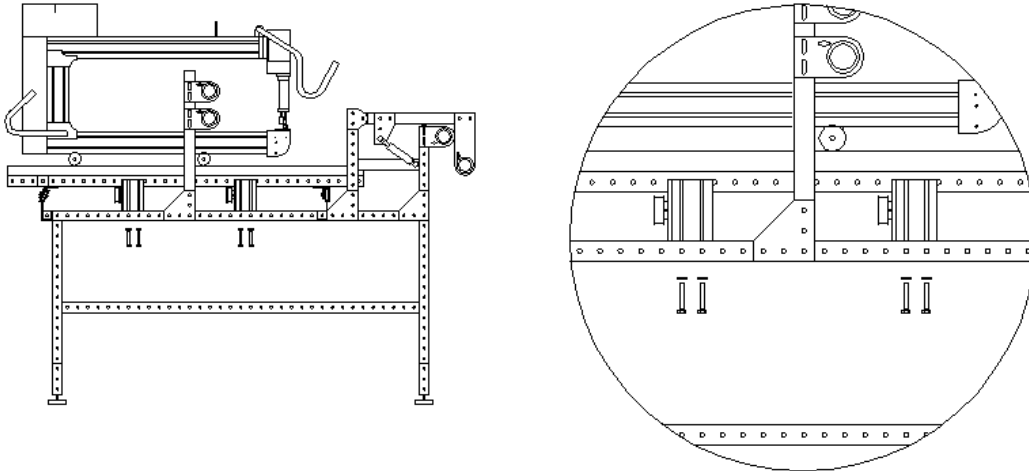

SECTION 3.0 MODIFICATIONS FOR 32" AUTOPILOT

Step 5: Install the Y-axis idler pulley onto the inside of the right carriage rail 2 holes in front of the lower carriage rear wheel assembly using (2) 5/16 x 2-3/4" hex head bolt, (4) flat washers and (2) nylon insert lock nuts.

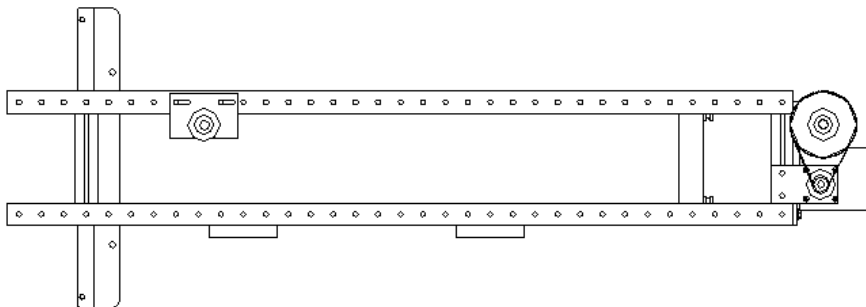

SECTION 5.0 MODIFICATIONS FOR 32" AUTOPILOT

Step 1: Attach the 48" touchscreen beam to the left or right side of the frame in the location illustrated below. Use (3) 1/4" x 2" socket head cap screws, (3) flat washers, (3) lock washers and (3) 1/4" t-nuts.

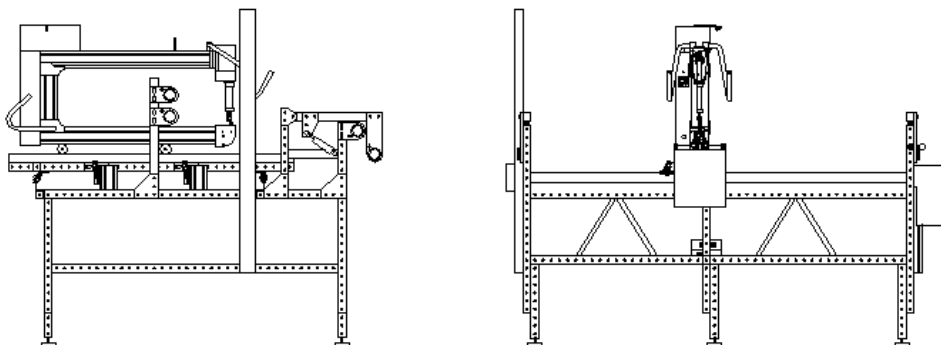

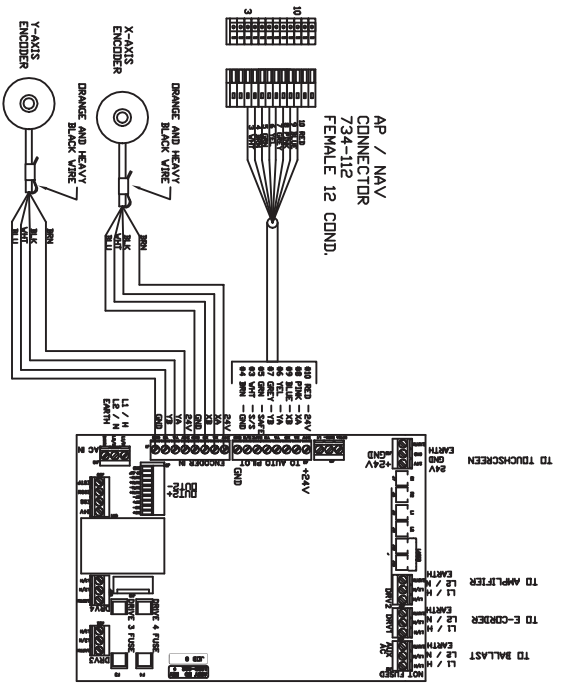
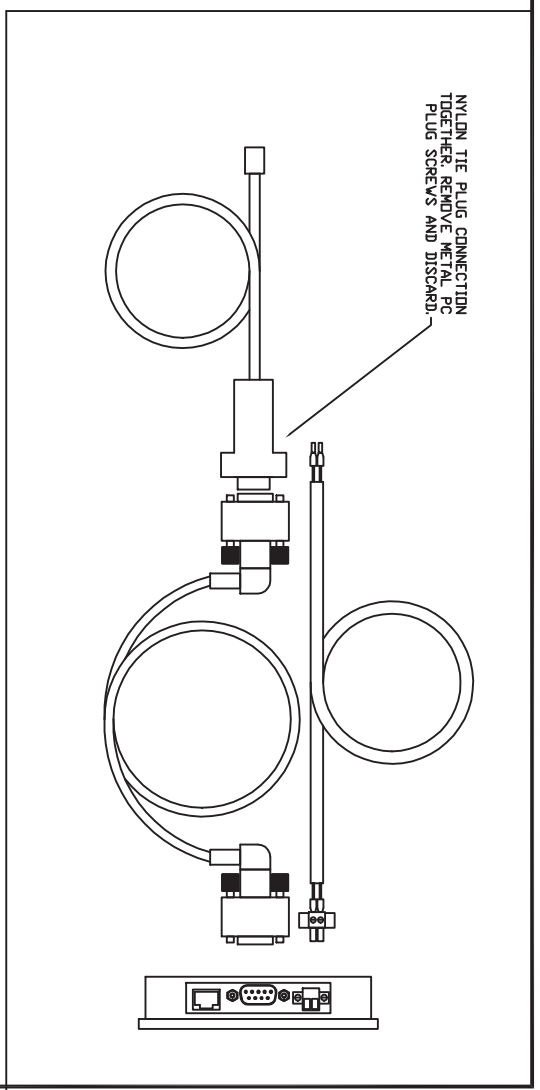
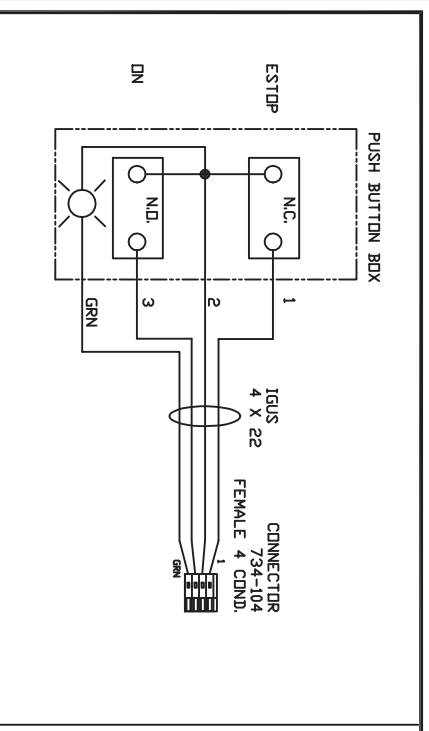

INCHES UNLESS OTHERWISE SPECIFIED			
ABM INTERNATIONAL 4541 WASHINGTON, INC. 211 SERRA AVENUE ELK GROVE VILLAGE, IL 60007			
TITLE: INNOVA TO AP/NAV CONTROL BOX FOR LIGHTNING SWITCH INNOVA			
DRAWN BY: JOE PODOLSKI		DATE: 1/29/13	
CHECKED BY:		DATE:	
FRONT SHEET	DRWG SHEETS	REVISIONS	DATE
1	2	E-PNO-0010	

IMPORTANT NOTE: WHEN INSTALLING AN AUTOPILOT DNTD MACHINES WITH THE NEW STYLE WHEEL BRACKETS, THE X WHT AND X BLK WIRES MUST BE SWAPPED. THIS MEANS THE WHITE WIRE MUST GO TO X BLK AND THE BLACK WIRE MUST GO TO X WHT. FAILURE TO DO SO WILL CAUSE INITIALIZATION ERRORS IN THE CONTROL BOX.

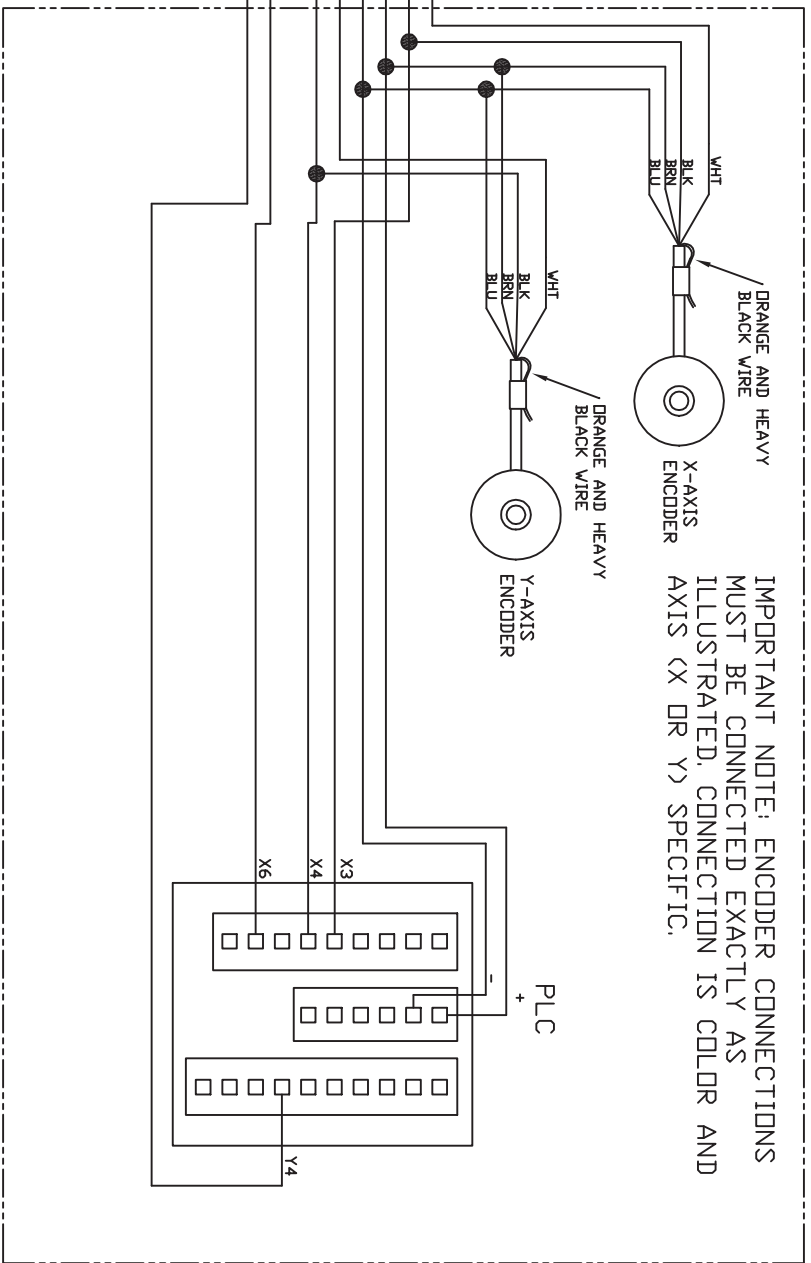
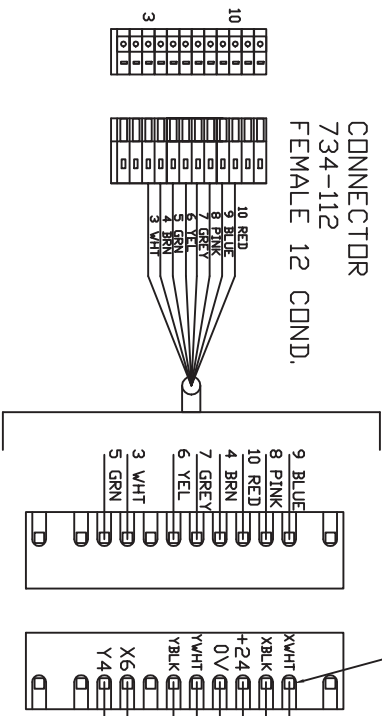

IMPORTANT NOTE: ENCODER CONNECTIONS MUST BE CONNECTED EXACTLY AS ILLUSTRATED. CONNECTION IS COLOR AND AXIS (X OR Y) SPECIFIC.